

Honeywell

PM45 and PM45c Interface Boards and Accessories

User Guide

Disclaimer

Honeywell International Inc. ("HII") reserves the right to make changes in specifications and other information contained in this document without prior notice, and the reader should in all cases consult HII to determine whether any such changes have been made. HII makes no representation or warranties regarding the information provided in this publication.

HII shall not be liable for technical or editorial errors or omissions contained herein; nor for incidental or consequential damages resulting from the furnishing, performance, or use of this material. HII disclaims all responsibility for the selection and use of software and/or hardware to achieve intended results.

This document contains proprietary information that is protected by copyright. All rights are reserved. No part of this document may be photocopied, reproduced, or translated into another language without the prior written consent of HII.

Copyright © 2023 Honeywell Group of Companies. All rights reserved.

Web Address: www.sps.honeywell.com

Trademarks

Microsoft® Windows® and the Windows logo are trademarks or registered trademarks of Microsoft Corporation.

Wi-Fi is a registered certification mark of the Wi-Fi Alliance.

Bluetooth is a trademark of Bluetooth SIG, Inc., U.S.A.

Other product names or marks mentioned in this document may be trademarks or registered trademarks of other companies and are the property of their respective owners.

For patent information, refer to www.hsmpats.com.

TABLE OF CONTENTS

Customer Support	vii
Technical Assistance	vii
Product Service and Repair	vii
Limited Warranty	vii
Safety Warnings	vii
Caution Statements	vii
Chapter 1 - Introduction	1
Interface Boards	1
Accessories	1
Back Ports and Slots	2
Set Up Printer for Installing Board/Accessories	3
Remove Media Cover	3
Remove Electronics Cover	5
Remove Front Access Door	6
Chapter 2 - Installing Interface Boards	7
Industrial Interface Board	7
Printer Firmware	7
Out of the Box	7
Installation	8
Serial Interface	11
RS232 Non-isolated (Standard)	11
RS-422 Isolated, Full Duplex (reconfiguration required)	13
RS-485 Isolated, Full Duplex (reconfiguration required)	14

Industrial Interface.....	15
Digital Opto In	15
Digital Opto Out.....	16
Relays.....	17
IEEE 1284 Parallel Board.....	19
Out of the Box	19
Installation.....	19
Parallel Interface	22
Connector Configuration.....	22
RFID Interface Board.....	23
Out of the Box	23
Installation.....	23
Installing RFID Antenna.....	24
Install the RFID Board Assembly	26
Applicator Interface Board.....	29
Printer Firmware.....	29
Out of the Box	29
Installing the Applicator Interface Board	30
Interfacing.....	32
Z-Style Port.....	33
S-Style Port	35
External Power Port	36
External Error Port	37
Applicator Signals.....	37
Configuring Applicator Port Settings.....	39
Web Browser Interface.....	39
Setup Mode.....	40
About Applicator Input Signals.....	40
About Applicator OUT Signals.....	40
Programming Applications for the printer.....	41
Fingerprint Commands for the printer	41

ON PORTIN.....	42
PORTIN.....	42
PORTOUT.....	42
ON PORTOUT.....	42
Using External Applicator Signals.....	43
Fingerprint and Applicator Signals.....	43
Direct Protocol and Applicator Signals.....	45
Error Messages.....	46
Display Messages.....	48
Wi-Fi/Bluetooth Interface Board.....	49
Out of the box.....	49
Installation.....	49

Chapter 3 - Installing Accessories.....51

Label Dispenser.....	51
Out of the Box.....	51
Installation.....	51
Cutter Module.....	54
Installing Cutter Module for PM45 Printer.....	54
Installing Cutter Module for PM45c Printer.....	58
3-inch Media Core.....	63
Out of the Box.....	63
Installation.....	63
Collapsible Core.....	64
Out of the Box.....	64
Installation.....	64
Full Batch Rewinder.....	67
Out of the Box.....	67
Installation.....	67
Large Media Edge Arm Guide.....	72
Out of the Box.....	72
Installation.....	72
Short Media Cover.....	75
Out of the Box.....	75

Installation.....	75
Dome Media Cover.....	78
Out of the Box	78
Installation.....	78
Thermal Printhead.....	81
Out of the Box	81
Installation.....	81
Appendix A - Wall Mounting Template	83
PM45 Wall Mounting Template.....	83
PM45c Wall Mounting Template.....	84

Customer Support

Technical Assistance

Go to www.honeywell.com/PSStechnicalsupport to search our knowledge base for a solution or to log into the Technical Support portal.

Product Service and Repair

Honeywell International Inc. provides service for all of its products through service centers throughout the world. Go to www.sps.honeywell.com and select Support to find a service center near you or to get a Return Material Authorization number (RMA #) before returning a product.

Limited Warranty

For warranty information, go to www.sps.honeywell.com and click **Support > Warranties**.

Safety Warnings



Warning: Do not put your fingers inside the print mechanism when the power is on.



Warning: This printer contains a coin battery and is NOT user replaceable. Keep children away from the printer when the printer is in service.

Never put batteries in your mouth as swallowing may lead to serious injury or death. If swallowed, seek medical attention immediately from a physician or local poison control center.

Caution Statements



Caution: Observe all safety and accident prevention regulations applicable to your specific region and application.



Caution: You must implement both hardware and software safety precautions to prevent the possibility of undefined system states.



Caution: You must make sure that dangerous conditions cannot occur under any circumstances, even for a brief period of time.



Caution: To reduce the risk of electric shock or fire, keep the cover closed and turn off the printer when not in use. There are no user-serviceable parts inside the power supply unit.

INTRODUCTION

Honeywell offers a full range of optional interface boards and accessories for the PM45 and PM45c printers.

The interface boards included in this guide are compatible with both PM45 and PM45c printers.

Interface Boards

- [Industrial Interface Board](#)
- [IEEE 1284 Parallel Board](#)
- [RFID Interface Board](#)
- [Applicator Interface Board](#)
- [Wi-Fi/Bluetooth Interface Board](#)

Accessories

There are multiple accessories available for PM45 and PM45c printers, see the table below for compatibility of each accessory.

Accessory	Compatible with PM45/PM45c/Both
Label Dispenser	Both
Cutter Module	Both
3-inch Media Core	Both
Collapsible Core	Both
Full Batch Rewinder	PM45
Large Media Edge Arm Guide	PM45
Short Media Cover	PM45c
Dome Media Cover	PM45c

Accessory	Compatible with PM45/PM45c/Both
Thermal Printhead	Both



Caution: Read and review the warnings in this manual carefully before connecting the printer.

Back Ports and Slots

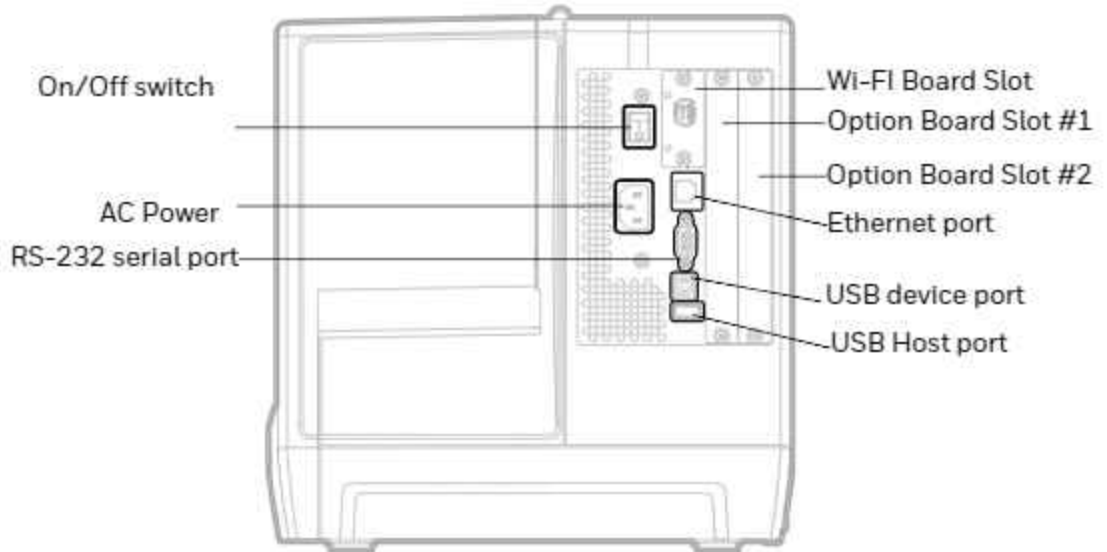

Set Up Printer for Installing Board/Accessories

You need to remove both the media cover and the electronics cover to install the interface boards or accessories.

You will require the below tools to remove the media and electronics cover.

- #T20 Torx Screwdriver
- Small wrench.



Caution: Before you begin, turn off the printer and disconnect the power cord and communication cables.

Remove Media Cover

To remove the media cover for PM45 printer,

1. Open the media cover.



2. Use the screwdriver and rotate counterclockwise to remove the four torx screws that secures the media cover in place.

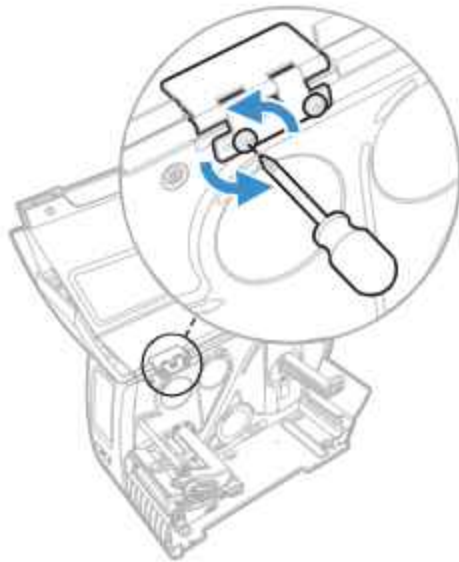

3. Lower the media cover and lift it off the hinges.
4. Put the media cover aside on a soft cloth to avoid scratches.

To remove media cover for PM45c printer,

1. Open the media cover.
2. Use a small wrench to loosen the nut that secures the media cover latches in place.
3. Slide the latches counterclockwise into the open position.

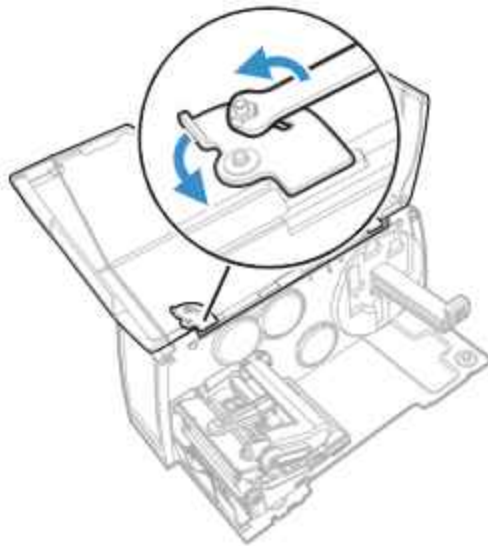

4. Close the media cover and lift it off the hinges.

Remove Electronics Cover

To remove the electronics cover,

1. Remove the media cover.
2. Use a T20 Torx screwdriver to remove the two screws that secure the electronics cover to the inside of the printer base.

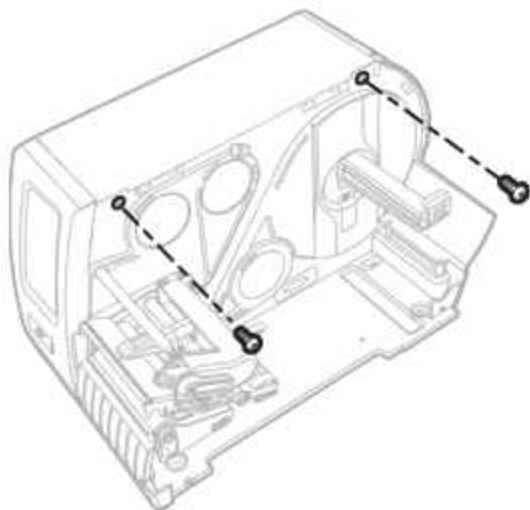

3. Use a T20 Torx screwdriver to remove the two screws located on the outside of the electronics cover.

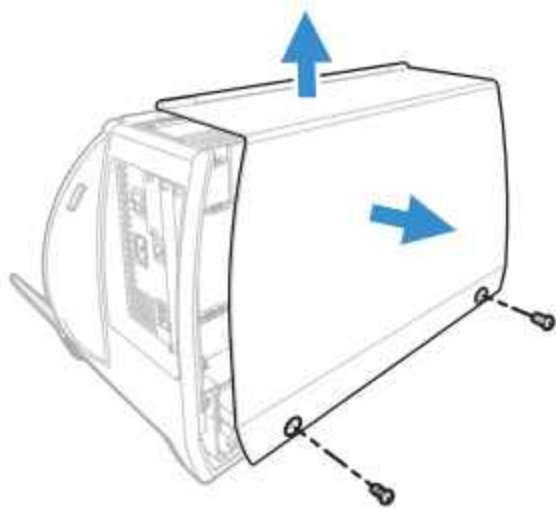

4. Remove the electronics cover, and put the cover aside on a soft cloth to avoid scratches.

Remove Front Access Door

To remove the access door for PM45 printer,

1. Open the access door and lift it out and away from the printer.

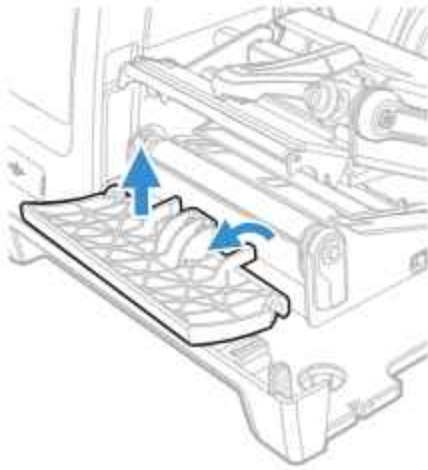

To remove the access door for PM45c printer,

1. Open the access door, remove the T20 screw that attaches it to the printer and slide it out and away from the printer.

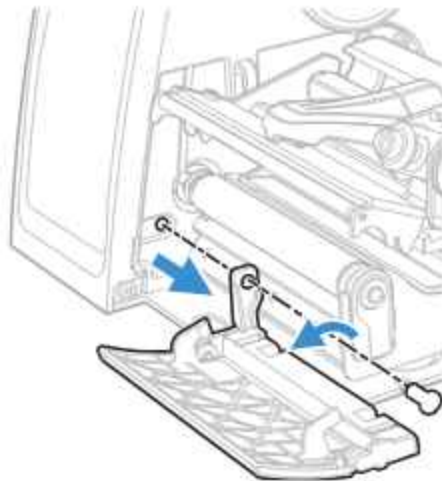

For more information about available accessories, see the PM45 product page at www.sps.honeywell.com. Contact your local sales representative for ordering information.

Industrial Interface Board

This section describes how to physically install the Industrial Interface Board in the printer and how to configure the serial communication port.

Printer Firmware

The printer must be fitted with Honeywell Fingerprint v10.18.00.0015 (or later).

Note: *The kit supports only Fingerprint and Direct Protocol command languages.*

In Honeywell Fingerprint, the serial ports are addressed as uart2 (communication channel#2)

Out of the Box

The Industrial Interface Kit includes:

- One Industrial Interface Board
- Two USB cables
- One spacer screw
- One 3x8mm Torx screw
- Two 4x8mm Torx screws
- Five straps

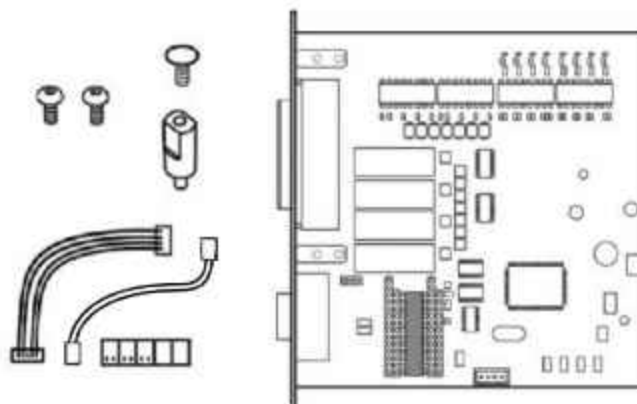

The tools needed for installation are #T10 and #T20 Torx screwdrivers.

Installation



Warning: The installation described in this section must only be performed by an authorized service technician. Honeywell assumes no responsibility for personal injury or damage to the equipment if the installation is performed by an unauthorized person.



Caution: Follow standard ESD guidelines to avoid damaging the equipment.



Caution: Before you begin, turn off the printer and disconnect the power cord and communication cables.

Follow the procedure to physically install the Industrial Interface board in the printer.

1. Turn off the printer and disconnect the power cord.
2. Remove the media cover (See [page 3](#)).
3. Remove the electronics cover (See [page 5](#)).

4. On the back of the printer, remove the two screws that secure the cover plate to the printer, and remove the cover plate.

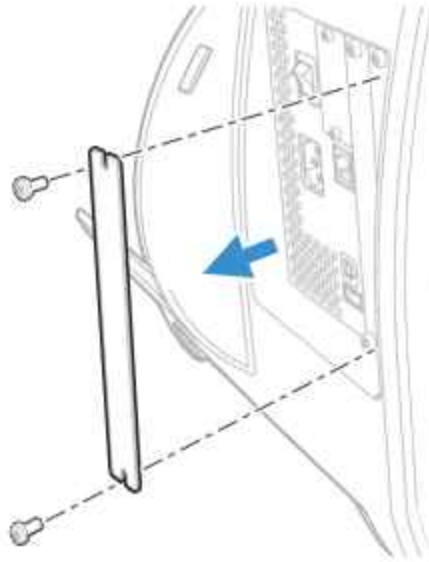

5. Use the T10 screwdriver to remove the screw located on the top of the printer main board and attach the space saver screw.
6. Insert the Industrial Interface Board into the printer and secure the board assembly to the printer with two screws.

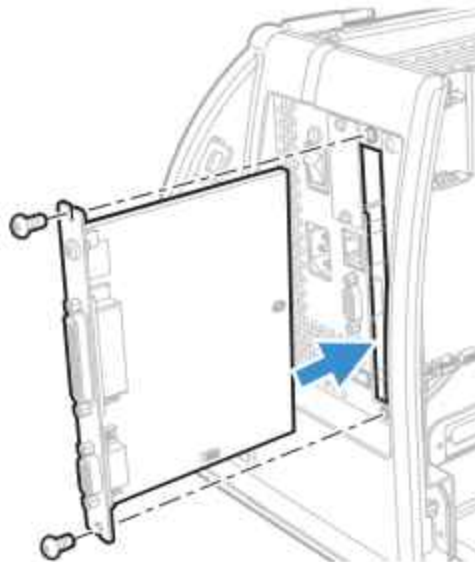

7. Secure the optional board assembly to the spacer with a Torx screw.

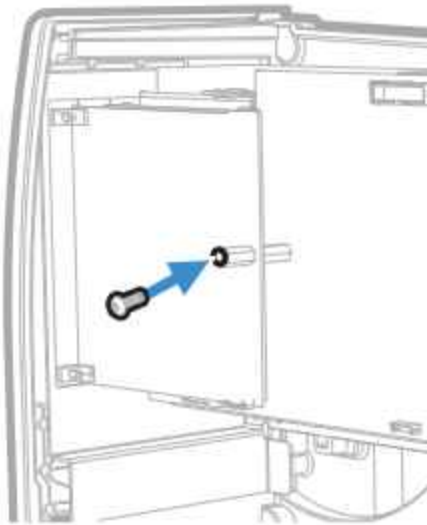

8. Insert the USB cable into the J38 or J37 connector on the printer main board. Then insert the other end into the J13 connector on the Industrial Interface Board.

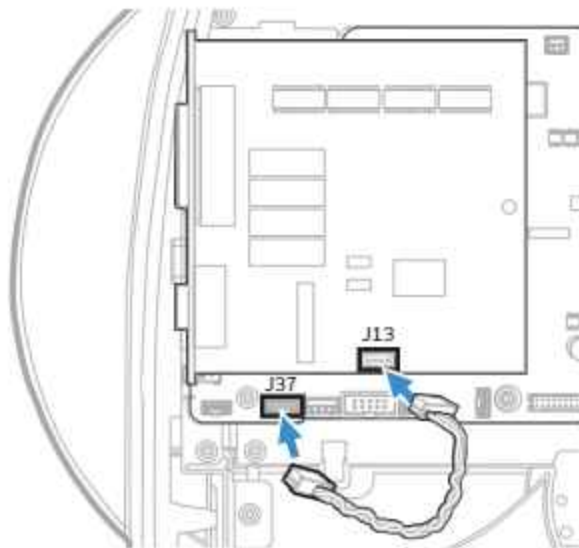

9. Fit the straps and circuits on the board to configure the type of serial communication you want to use. For more details, see Serial Interface.
10. Put the cover back and secure it with the 4 screws.

Serial Interface

This section describes how to modify the interface board for RS-232 (standard), RS-422 isolated/full duplex, or RS-485 isolated/half duplex on the "uart2:" port and explains the configuration of the interface connector.

One of the circuits shown below will be needed for the serial communication you want to use.

Serial Communication	Honeywell Part Number	Integrated Circuit	Remark
RS-232 Non-isolated	360-018-001	Maxim 238	Already mounted on board
RS-422 isolated full duplex	360-027-001	Maxim 1490 full duplex RS485/422 Intfc, 250Kbps RoHS	Not included in kit, needs to be purchased
RS-485 isolated half duplex	360-026-001	Maxim 1480 half duplex RS485/422 Intfc, 250Kbps RoHS	Not included in kit, needs to be purchased



Warning: When fitting driver circuit and straps before installing the interface board, make sure the circuit is not fitted upside down. Protect the board and circuits from the electrostatic charges

RS232 Non-isolated (Standard)

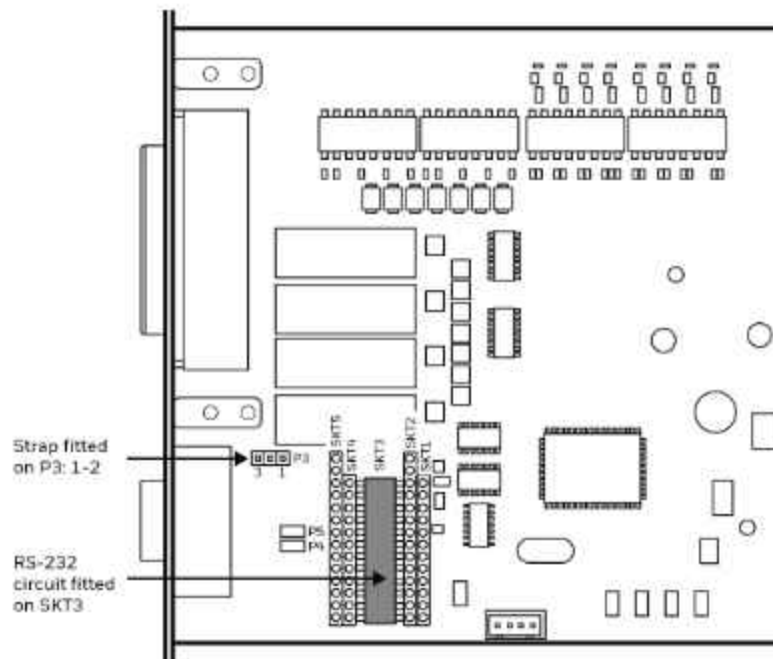

Connector Configuration (RS-232 on "uart2")

RS-232 Socket	Pin of DB9	Signal Name	Description
	1	+5VDC	External +5VDC max 600mA (automatic switch off at overload, short-circuit protected)
	2	TXD	Transmit data
	3	RXD	Receive data
	4	DSR	Data set ready
	5	GND	Ground
	6	DTR	Data terminal ready
	7	CTS	Clear to send
	8	RTS	Request to send
	9	-	-

RS-422 Isolated, Full Duplex (reconfiguration required)

Note: The RS-422 circuit is available as a spare part.

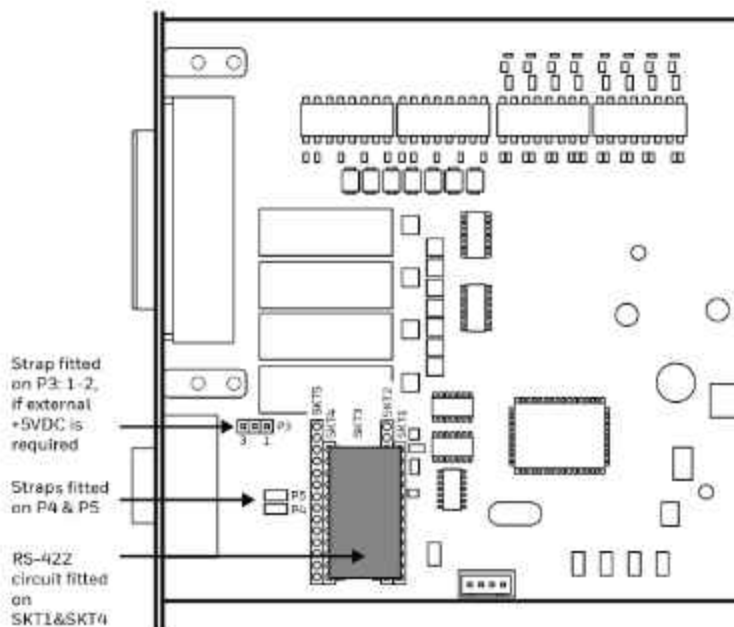

Connector Configuration (RS-422 on "uart2")

RS-422 Socket	Pin of DB9	Signal Name	Description
	1	+5VDC	External +5VDC max 600mA (automatic switch off at overload, short-circuit protected) provided strap is fitted on P3:2-3 which spoils the galvanic isolation
	2	+TXD	+Transmit data
	3	+RXD	+Receive data
	4	-	
	5	GNDE	Ground
	6	-	
	7	-RXD	-Receive data
	8	-TXD	-Transmit data
	9	-	

RS-485 Isolated, Full Duplex (reconfiguration required)

Note: The RS-485 circuit is available as a spare part.

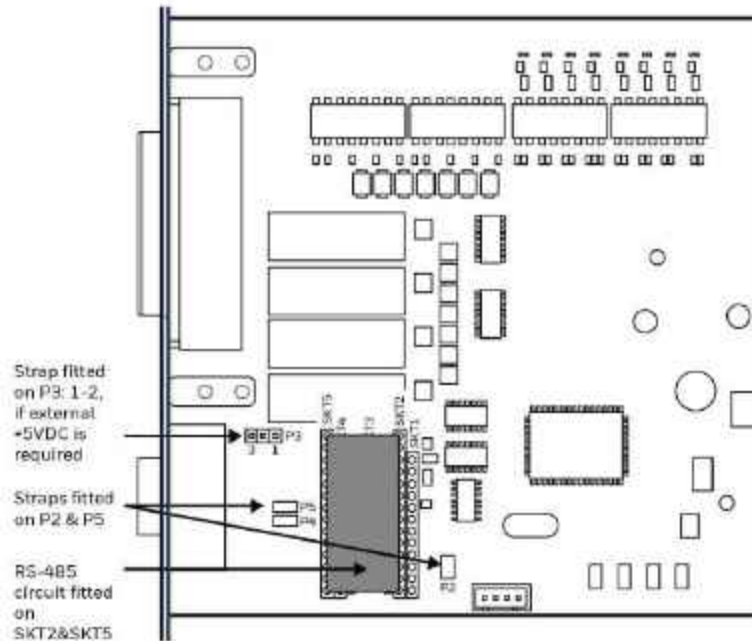

Connector Configuration (RS-485 on "uart2")

RS-485 Socket	Pin of DB9	Signal Name	Description
	1	+5VDC	External +5VDC max 600mA (automatic switch off at overload, short-circuit protected) provided strap is fitted on P3:2-3 which spoils the galvanic isolation
	2	+DATA	
	3	-	
	4	-	
	5	GNDE	Ground
	6	-	
	7	-	
	8	-DATA	
	9	-	

Note: The increased use of LAN networks has made the RS-485 interface somewhat obsolete, because RS-485 requires a special communication protocol and a dedicated wiring system limited to 1,200 m(4000ft). We only recommend RS-485 for existing application and advise the customer to consider a LAN network solution for new applications.

Industrial Interface

The Industrial Interface, provides 8 digital IN ports with optocouplers, 8 digital OUT ports with optocouplers, and 4 OUT ports with relays.

The industrial interface has no straps or circuits to be fitted or removed. All signals are available on a DB-44pin socket and the various ports are controlled by the Honeywell Fingerprint Instructions PORTIN and PORTOUT ON/OFF.

For more information, see the Honeywell Fingerprint Command Reference Manual at www.sps.honeywell.com.

Digital Opto In

The status of the digital IN ports can be read using the PORTIN functions. If a current is led through the optocoupler of the port, PORTIN returns the value -1 (true) or value 0 (false).

Signal	Description	Min	Typical	Max
Vin (High)	Input voltage high	10V	24V	40V
Vin (Low)	Input voltage low	-1V	0V	1V

Connector Configuration

Pin of DSUB 44	Signal Name	Description	Fingerprint Ref. No.
10	IN1A	Anode Opto In Channel 1+	101
40	IN1K	Cathode Opto In Channel 1-	
26	IN2A	Anode Opto In Channel 2+	102
11	IN2K	Cathode Opto In Channel 2-	
41	IN3A	Anode Opto In Channel 3+	103
27	IN3K	Cathode Opto In Channel 3-	
12	IN4A	Anode Opto In Channel 4+	104
42	IN4K	Cathode Opto In Channel 4-	
28	IN5A	Anode Opto In Channel 5+	105
13	IN5K	Cathode Opto In Channel 5-	
43	IN6A	Anode Opto In Channel 6+	106
29	IN6K	Cathode Opto In Channel 6-	
14	IN7A	Anode Opto In Channel 7+	107
44	IN7K	Cathode Opto In Channel 7-	
30	IN8A	Anode Opto In Channel 8+	108
15	IN8K	Cathode Opto In Channel 8-	

Simplified schematics of a digital IN port:

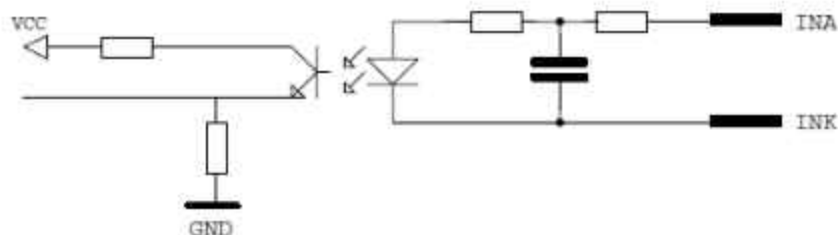

Digital Opto Out

The current to each optocoupler of the digital OUT ports can be turned on and off using PORTOUT ON/OFF statements. The status of the ports can be read using PORTIN functions. If a current is led through the optocoupler of the port, PORTIN returns the value -1 (true), else it returns the value 0 (false).

Signal	Description	Max
V _{ceo}	Collector - emitter Breakdown Voltage	35V
V _{eco}	Emitter - collector breakdown voltage	6V
I _c	Collector current (non-saturation)	30mA

Connector Configuration:

Pin of DSUB 44	Signal Name	Description	Fingerprint Ref. No.
20	OUT_1C	Collector Opto Out Channel 1	221
5	OUT_1E	Emitter Opto Out Channel 1	
35	OUT_2C	Collector Opto Out Channel 2	222
21	OUT_2E	Emitter Opto Out Channel 2	
6	OUT_3C	Collector Opto Out Channel 3	223
36	OUT_3E	Emitter Opto Out Channel 3	
22	OUT_4C	Collector Opto Out Channel 4	224
7	OUT_4E	Emitter Opto Out Channel 4	
37	OUT_5C	Collector Opto Out Channel 5	225
23	OUT_5E	Emitter Opto Out Channel 5	
8	OUT_6C	Collector Opto Out Channel 6	226
38	OUT_6E	Emitter Opto Out Channel 6	
24	OUT_7C	Collector Opto Out Channel 7	227
9	OUT_7E	Emitter Opto Out Channel 7	
39	OUT_8C	Collector Opto Out Channel 8	228
25	OUT_8E	Emitter Opto Out Channel 8	

Simplified schematics of a digital OUT port:

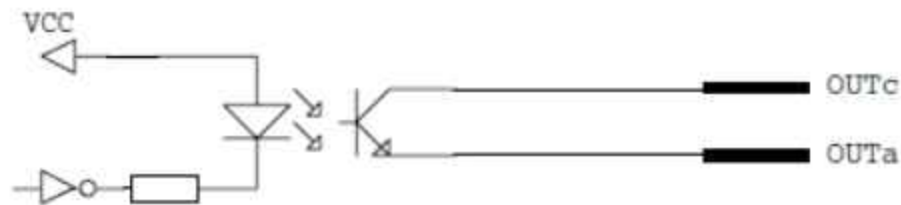

Relays

The relays of the OUT ports can be individually activated using PORTOUT ON/OFF statements. The status of the ports can be read by means of PORTIN functions. If a relay is activated, PORTIN returns the value -1 (true), else it returns the value 0 (false).

Signal	Description	Max
I	Current	1A
P _{sw AC}	Switching power	100VA AC
U _{sw AC}	Switching voltage	100V AC

Connector Configuration:

Pin of DSUB 44	Signal Name	Description	Fingerprint Ref. No.
16	REL1NC	Relay 1 Normally Closed	201
1	REL1NO	Relay 1 Normally Open	
31	REL1COM	Relay 1 Common	
17	REL2NC	Relay 2 Normally Closed	202
2	REL2NO	Relay 2 Normally Open	
32	REL2COM	Relay 2 Common	
18	REL3NC	Relay 3 Normally Closed	203
3	REL3NO	Relay 3 Normally Open	
33	REL3COM	Relay 3 Common	
19	REL4NC	Relay 4 Normally Closed	204
4	REL4NO	Relay 4 Normally Open	
34	REL4COM	Relay 4 Common	

Simplified schematics of a relay OUT port:

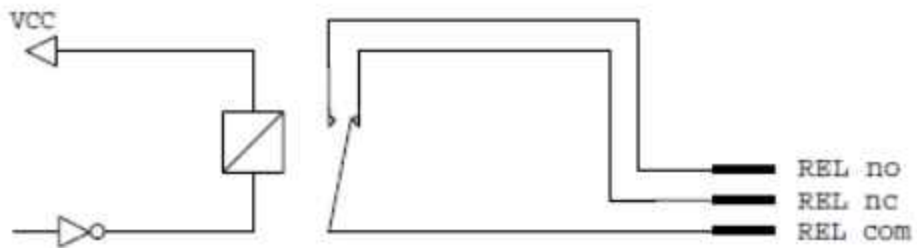

IEEE 1284 Parallel Board

This section describe how to install the IEEE1284 Parallel port interface board and the connector configuration.

Out of the Box

- One IEEE 1284 Parallel Port Board
- One USB cable

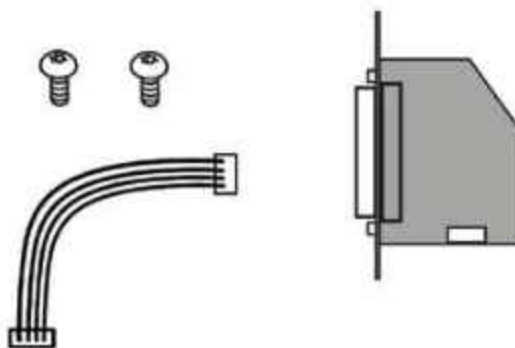

The only tools required for installation are the #T10 and #T20 Torx screwdrivers.

Installation



Warning: The installation described in this section must be only performed by an authorized service technician. Honeywell assumes no responsibility for personal injury or damage to the equipment if the installation is performed by an unauthorized person.



Caution: Follow standard ESD guidelines to avoid damaging the equipment.



Caution: Before you begin, turn off the printer and disconnect the power cord and communication cables.

Follow the procedure to physically install the IEEE1284 Parallel Port Board in the PM45/PM45c printer.

1. Turn off the printer and disconnect the power cord.
2. Remove the media cover (See [page 3](#)).
3. Remove the electronics cover (See [page 5](#)).
4. On the back of the printer, remove the two screws that secure the cover plate to the printer, and remove the cover plate.

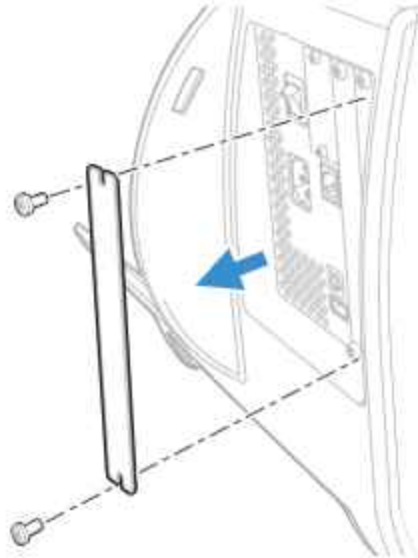

5. Insert the parallel port board into the printer, and secure the board with the two screws you removed in Step 4.

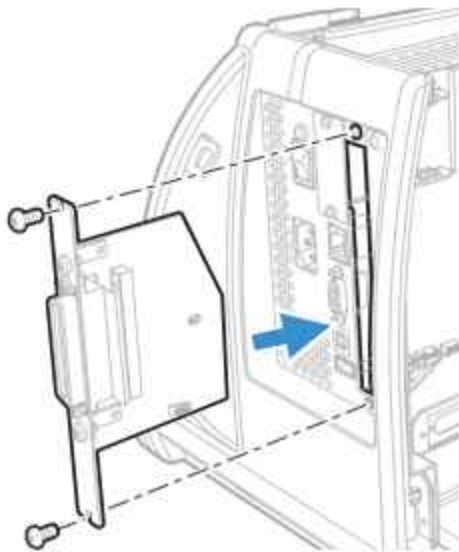

6. Insert the USB cable into the J38 connector on the printer main board. Then insert the other end into the J2 connector on the Parallel Board.

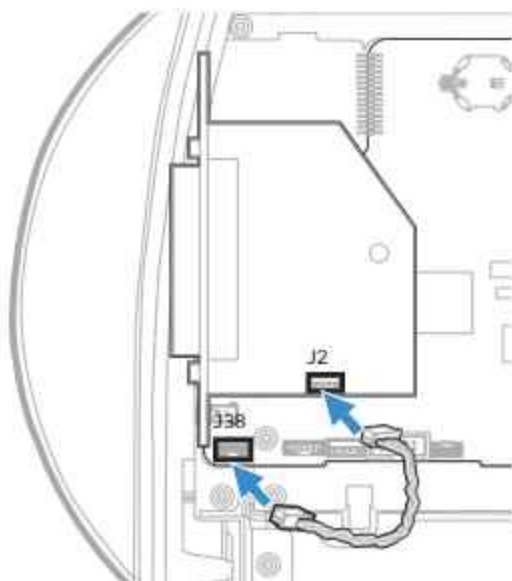

7. Replace the electronics cover.
8. Replace the media cover.

Parallel Interface

This section describes the signals on the connector of the IEEE 1284 interface board.

Connector Configuration

The IEEE 1284 board has a standard 36pin IEEE 1284 B socket with the following configuration.

Pin	Signal	Remark
1	DSTROBE	
2	DATA0	+Transmit data
3	DATA1	+Receive data
4	DATA2	
5	DATA3	Ground
6	DATA4	
7	DATA5	-Receive data
8	DATA6	-Transmit data
9	DATA7	
10	ACK	
11	BUSY	
12	PE	
13	SELECT	
14	AF	
15	N/C	Not Connected
16	GND	
17	SCREEN	
18	-	External +5VDC max 500mA (automatic switch-off at overload, short-circuit protected)
19-30	GND	
31	INIT	
32	ERROR	
33-35	N/C	Not Connected
36	SELECTIN	

RFID Interface Board

This section describe how to install the RFID interface board and the connector configuration.

Out of the Box

- One RFID interface board
- RFID antenna
- One antenna cable
- Two USB cables
- One spacer screw
- Two Torx screws

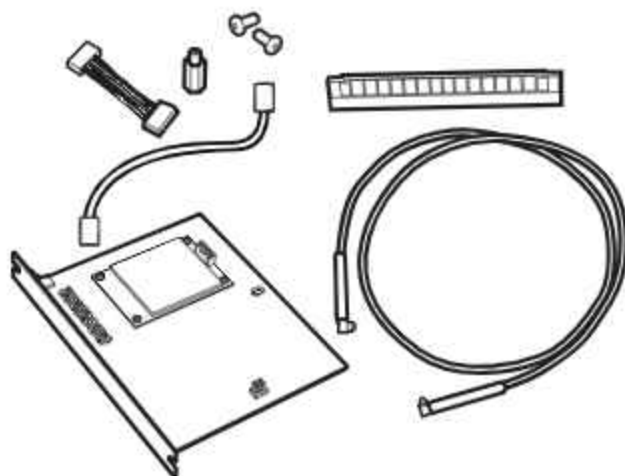

You will also need a #T10 and #T20 screwdriver and a small wrench.

Installation

To install the RFID module, you need to open the printer and physically install the module in the printer.

Before you install the RFID module, you need to first install the RFID antenna.

- Installing RFID antenna
- Installing RFID interface board



Warning: The installation described in this section must be only performed by an authorized service technician. Honeywell assumes no responsibility for personal injury or damage to the equipment if the installation is performed by an unauthorized person.



Caution: Follow standard ESD guidelines to avoid damaging the equipment.



Caution: Before you begin, turn off the printer and disconnect the power cord and communication cables.

1. Turn off the printer and disconnect the power cord.
2. Remove the media cover (See [page 3](#)).
3. Remove the electronics cover (See [page 5](#)).

Installing RFID Antenna

1. Turn the printhead lever counterclockwise to raise the printhead.
2. Remove the tear bar.

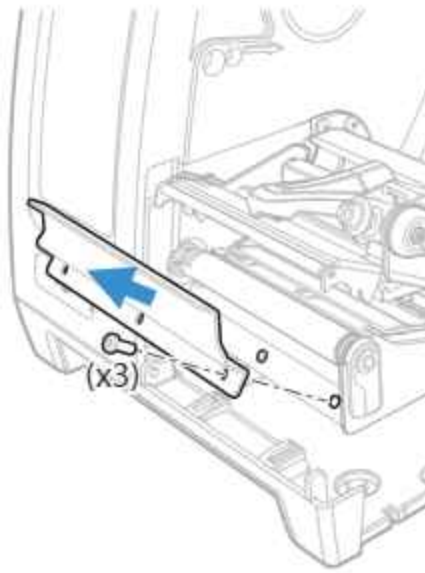

3. Turn the platen roller release lever clockwise and slide the platen roller away from the printer.

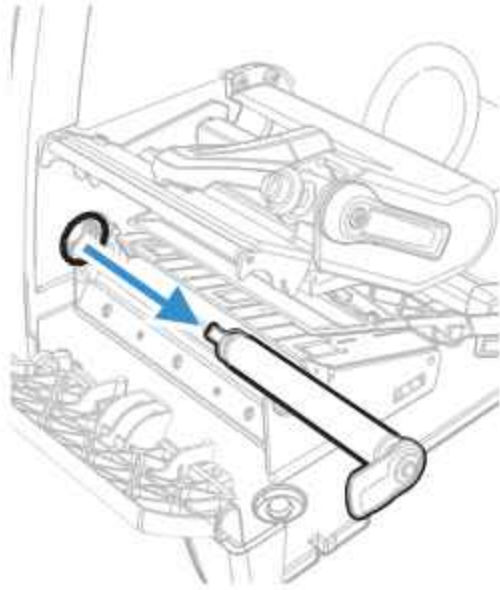

4. Feed the antenna cable through the round cutout from the electronics side of the printer. Connect the antenna cable to the antenna cable jack on the RFID antenna.

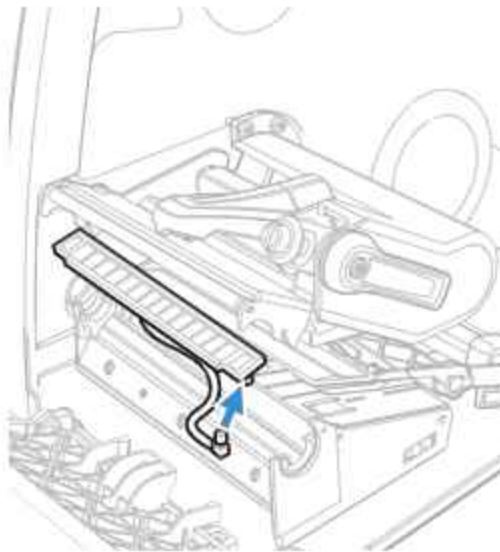

5. Insert the RFID antenna into the media guide assembly. Make sure that both the antenna cable and media guide wires are not pinched between the media

guide assembly and inside wall of the printer base.

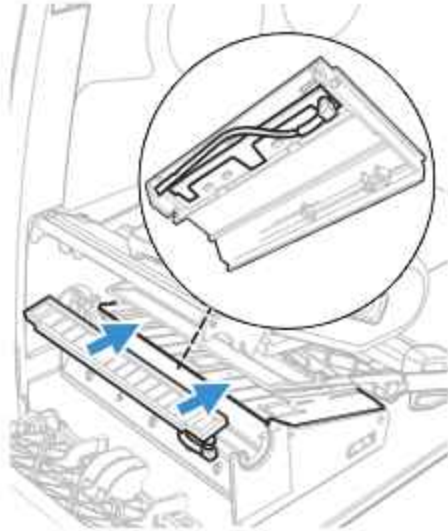

6. Replace and secure the tear bar and platen roller.

Install the RFID Board Assembly

1. On the back of the printer, remove the two screws that secure the cover plate to the printer, and remove the cover plate.

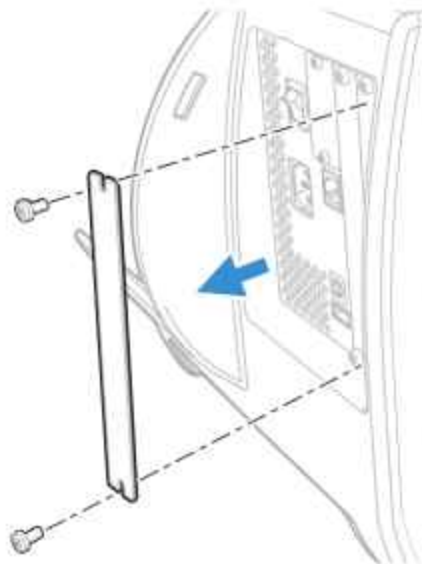

2. Attach the spacer screw to the center of the printer main board.

3. Insert the RFID board into the printer and secure the board using a #T20 screwdriver on the printer.

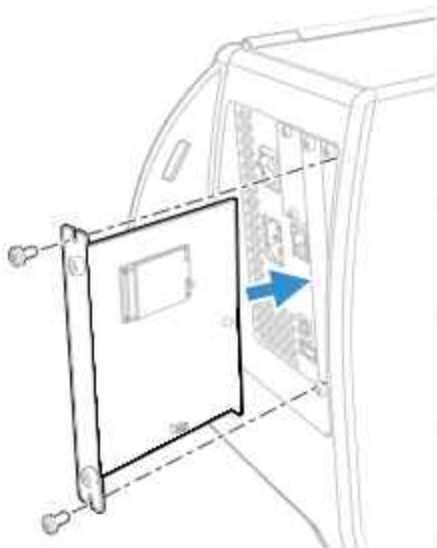

4. Route the antenna cable through the electronics side of the printer and connect the antenna cable to the cable jack on the RFID board assembly.

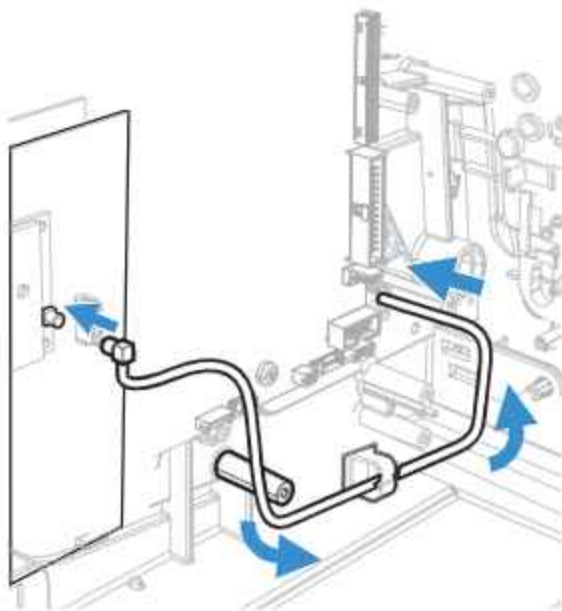

5. Insert the USB cable into the J37 or J38 connector on the printer main board. Then insert the other end into the J3 connector on the RFID Board.

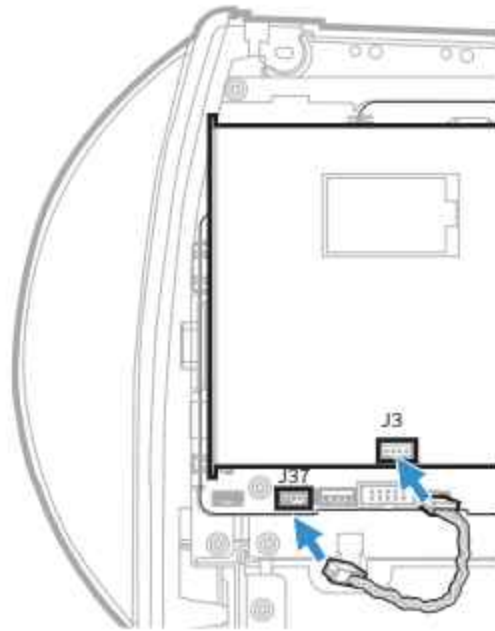

6. Replace the electronics cover.
7. Replace the media cover.

Applicator Interface Board

This section describes how to physically install and configure the Applicator Interface Board in the PM45 and PM45c printers.

Printer Firmware

The printer must be fitted with Honeywell Fingerprint v10.18.00.0015 (or later).

Note: The kit supports only Fingerprint, Direct Protocol, and ZSim.

Out of the Box

The Applicator Interface Board installed kit includes:

- One Applicator Interface Board
- One power cable
- Two USB cables
- One spacer screw
- One 3x8mm Torx screw
- Two 4x8mm Torx screws

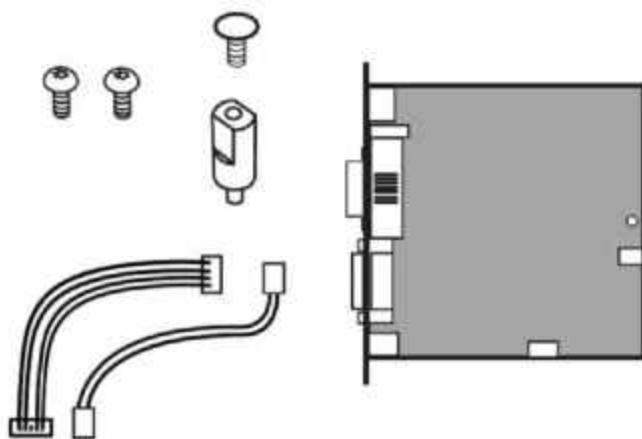

The only tools required for installation are the #T10 and #T20 Torx screwdrivers.

Installing the Applicator Interface Board



Warning: The installation described in this section must only be performed by an authorized service technician. Honeywell assumes no responsibility for personal injury or damage to the equipment if the installation is performed by an unauthorized person.



Caution: Follow standard ESD guidelines to avoid damaging the equipment.



Caution: Before you begin, turn off the printer and disconnect the power cord and communication cables.

Follow the procedure to physically install the Applicator Interface Board in the PM45 printer.

Note: This procedure applies to both the PM45 and PM45c printers. For simplicity, the PM45 is depicted in the illustrations.

1. Turn off the printer and disconnect the power cord.
2. Remove the media cover. (See [page 3](#)).
3. Remove the electronics cover. (See [page 5](#)).
4. Remove the two screws on the back of printer securing the cover plate and remove the cover plate.

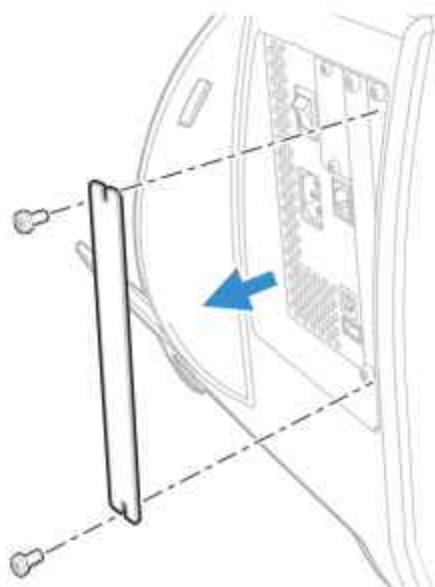

5. Use the T10 screwdriver to remove the screw located on top of the printer main board and replace with spacer screw.
6. Insert the applicator interface board into the printer and secure the board assembly to the printer with two torx screws.

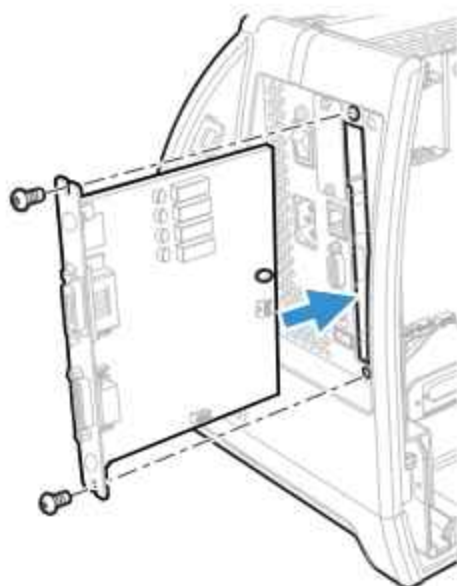

7. Secure the interface board assembly to the spacer screw with a Torx screw.
8. Insert the USB cable to the J38 or J37 connector on the printer main board and connect the other end to the J1 connector of the applicator board.

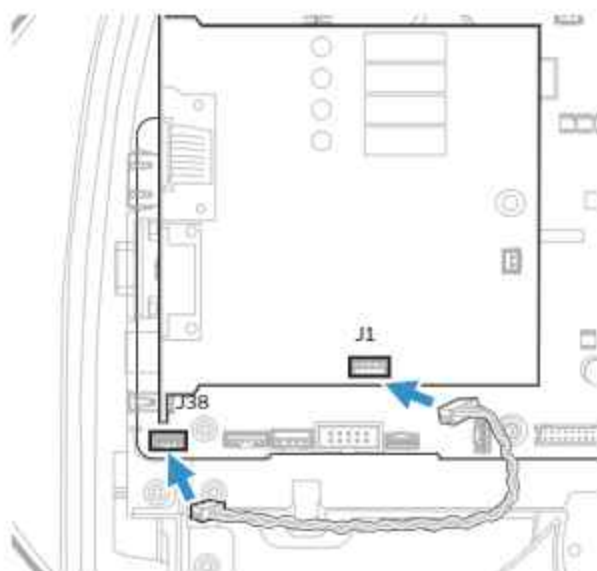

9. Insert the power cable J33 on the printer main board and connect the other end J2 on the of the applicator board.

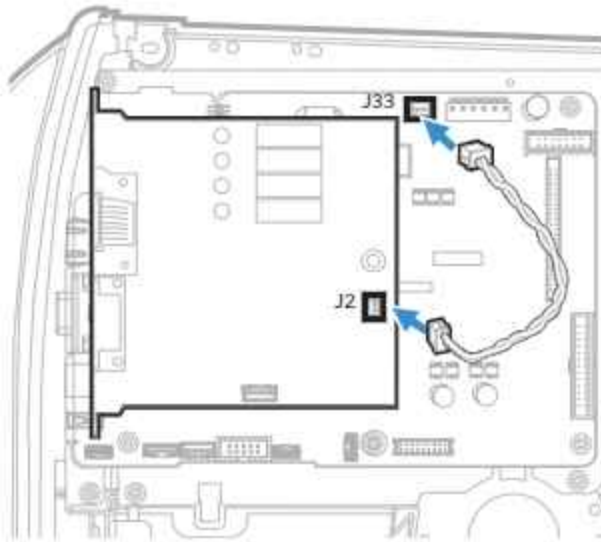

10. Put the electronics cover back on secure it with the 4 screws.
11. Put the media cover back on and secure it.

Interfacing

This option board contains 4 connectors for a Z-Style Port, an S-Style Port, an External Power Port, and an External Error Port.

Port	Description
Z-Style	A D-Sub 15Pin receptacle connector.
S-Style	A D Shaped SCSI 14Pin connector.
External Power	A Mini-DIN 6Pin receptacle connector.
External Error	A Mini-DIN 8Pin receptacle connector.

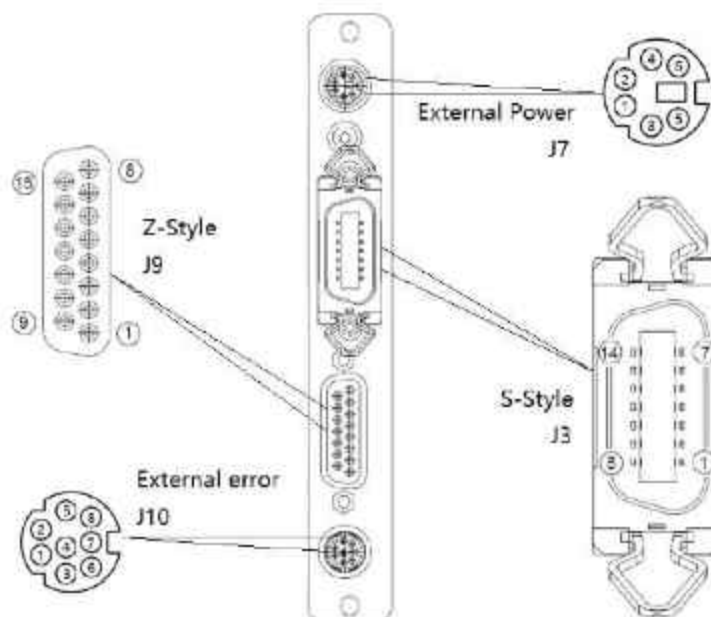

Z-Style Port

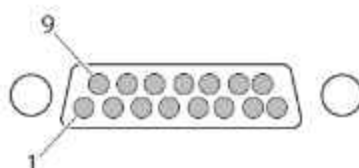

Z-Style Port Pinouts

Pin	Signal	Type	Description
1	Signal ground	Ground	configurable for internal or external source
2	+5VDC	Power	Voltage supply for external sensors. Configurable for internal or external source.
3	Start print	Input	<p>Pulse Mode - prints one and only one label whenever this pin is pulled to ground. Signal must be de-asserted and reasserted to print another label.</p> <ul style="list-style-type: none"> • Printing starts on HIGH to LOW transition if format is ready. • De-assert this signal to HIGH to inhibit printing. <p>Level Mode - prints labels continuously when this pin is pulled to ground. Printing is disabled when signal is de-asserted. If a label is printing when de-asserted, printing stops after the label is complete.</p> <ul style="list-style-type: none"> • Assert LOW to start printing if format is ready. • De-assert HIGH when current label has finished printing. Remains de-asserted while waiting for the next label to be ready to print.

Pin	Signal	Type	Description
4	Feed	Input	Assert LOW to feed label stock. De-assert HIGH to stop feeding labels.
5	Pause	Input	Assert LOW for 200ms and then de-assert HIGH to toggle between pause and un-pause states.
6	Reprint	Input	Reprint mode is enabled in software. When this mode is enabled, assert LOW to reprint last label. This input is ignored when reprint mode is disabled.
7	+24VDC	Output	Power for external devices: +24VDC ($\pm 10\%$) @ 2A.
8	Power ground	Ground	+24VDC return.
9	Ribbon/ Media low	Output	Goes LOW when the ribbon/media roll diameter drops below a predefined level, otherwise goes HIGH. Media low is supported only by I-Style.
10	Service required	Output	Goes LOW during every status that keeps the printer from printing: <ul style="list-style-type: none"> • Printhead lifted • Ribbon out • Media out • General print engine fault • Front arm lifted • Exceed maximum barcodes
11	End print	Output	Drives an applicator or other external device requiring synchronization with the print cycle. Choose between five types of output signals: <ul style="list-style-type: none"> • Mode 0: Applicator port is OFF. • Mode 1: Asserted LOW only when media is moving, otherwise de-asserted HIGH. • Mode 2: Asserted HIGH only when media is moving, otherwise de-asserted LOW. • Mode 3 (Default): Asserted LOW for 20ms when label has finished printing and positioned. Not asserted during continuous printing. • Mode 4: Asserted HIGH for 20 ms when label has finished printing and positioned. Not asserted during continuous printing.
12	Media out	Output	Goes LOW when the printer is out of media.
13	Ribbon out	Output	Goes LOW when the printer is out of ribbon.
14	Data ready	Output	Goes LOW when ready to print. De-asserted HIGH when printing cycle starts.
15	Reserved		

S-Style Port

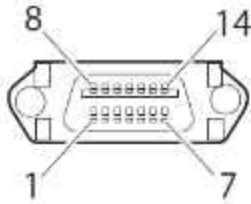

S-Style Port Pinouts

Pin	Signal	Type	Description
1	Media out	Output	Goes LOW when the printer is out of media.
2	Signal ground	Ground	Configurable for internal or external source.
3	Ribbon out	Output	Goes LOW when the printer is out of ribbon.
4	Error	Output	Goes LOW during every status that keeps the printer from printing: <ul style="list-style-type: none"> • Printhead lifted • Ribbon out • Media out • General print engine fault • Front arm lifted • Exceed maximum barcodes
5	Start print	Input	<p>Pulse mode - prints one and only one label whenever this pin is pulled to ground. Signal must be de-asserted and re-asserted to print another label.</p> <ul style="list-style-type: none"> • Printing starts on HIGH to LOW transition if format is ready. • De-assert this signal to HIGH to inhibit printing. <p>Level mode - prints labels continuously when this pin is pulled to ground. Printing is disabled when signal is de-asserted. If a label is printing when de-asserted, printing stops after that label is complete.</p> <ul style="list-style-type: none"> • Assert LOW to start printing if format is ready. • De-asserted HIGH when current label has finished printing. Remains de-asserted while waiting for next label to be ready to print.

Pin	Signal	Type	Description
6	End print	Output	Drives an applicator or other external device requiring synchronization with the print cycle. Choose between four types of output signals: <ul style="list-style-type: none"> • Type 1 (Default): Asserted LOW for 20ms when label has finished printing and positioned. Not asserted during continuous printing. • Type 2: Asserted HIGH for 20ms when label has finished printing and positioned. Not asserted during continuous printing. • Type 3: Asserted LOW only when media is moving, otherwise de-asserted HIGH. • Type 4: Asserted HIGH only when media is moving, otherwise de-asserted LOW.
7	Reprint	Input	Reprint mode is enabled in software. When this mode is enabled, assert LOW to reprint last label. This input is ignored when Reprint mode is disabled.
8	Reserved		
9	Reserved		
10	Ribbon/ Media low	Output	Goes LOW when the ribbon/media roll diameter drops below a predefined level, otherwise goes HIGH. Media low is supported only by I-Style.
11	Reserved		
12	+24VDC	Output	Power for external devices: +24VDC (+10%) @2A.
13	+5VDC	Power	Voltage supply for external sensors. Configurable for internal or external source.
14	Power ground	Ground	+24VDC return.

External Power Port

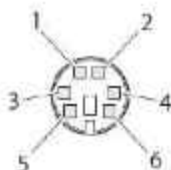

External Power Port Pinouts

Pin	Signal	Type	Description
1	+5VDC	Input	+5VDC input for distribution through Applicator Port connector (Z-Style pin 2, S-Style pin 13)
2	Signal ground	Input	Signal return for +5VDC supply (Z-Style pin 1, S-Style pin 2)
3	+24VDC	Input	+24VDC input for distribution through Applicator Port connector (Z-Style pin 7, S-Style pin 12)
4	Power ground	Input	Power return for input (Z-Style pin 8, S-Style pin 2)

Pin	Signal	Type	Description
5	+24VDC	Input	+24VDC input for distribution through Applicator Port connector (Z-Style pin 7, S-Style pin 12)
6	Power ground	Input	Power return for input (Z-Style pin 8, S-Style pin 2)

External Error Port

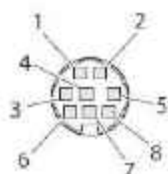

External Error Port Pinouts

Pin	Signal	Type	Description
1	AppErr_1	Input	Applicator error #1, reserved for external applicator device to signal error for printer to receive status of applicator.
2	AppErr_2	Input	Applicator error #2, reserved for external applicator device to signal error for printer to receive status of applicator.
3	AppErr_3	Input	Applicator error #3, reserved for external applicator device to signal error for printer to receive status of applicator.
4	RtW_in_Ext	Input	External input signal from the applicator to the printer, for the printer to switch to the same state with the applicator, and behave in sync as part of the entire system.
5	+5VDC	Output	Available for applicator.
6	RtW_Out	Output	External output signal indicating the printer is Ready to Work. Signal may be asserted LOW when there are no active events in the System Health Monitor (SHM), when the printer motor is idle, or both.
7	Ground	Ground	Available for applicator.
8	Ground	Ground	Available for applicator.

Applicator Signals

The diagrams below show how applicator signals function in each applicator mode during the stages of printing labels.

End Print Mode 1/Type 3

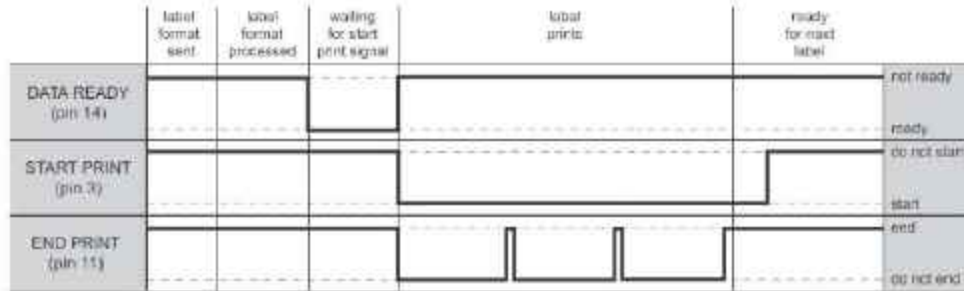

End Print Mode 2/Type 4

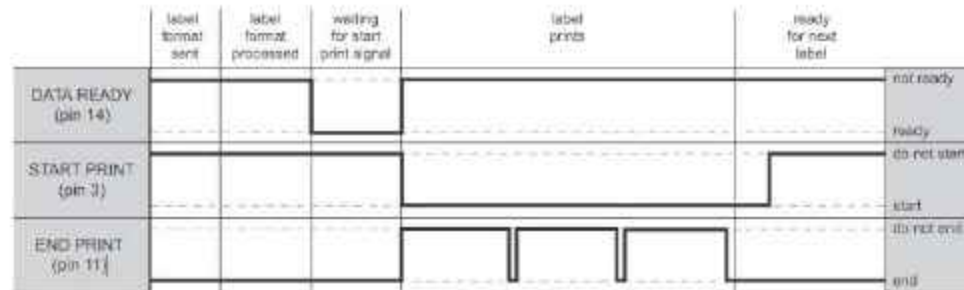

End Print Mode 3/Type 1

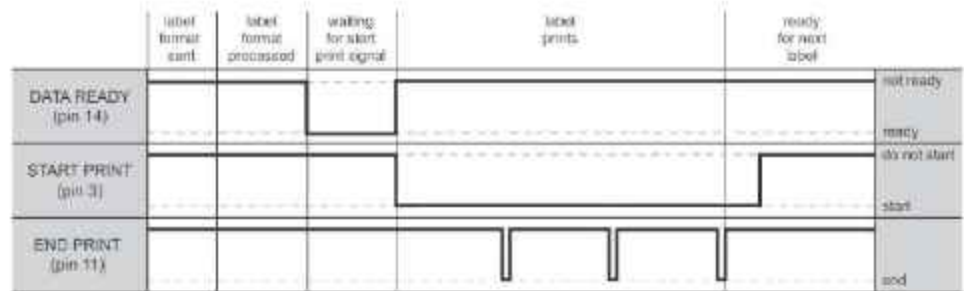

End Print Mode 4/Type 2

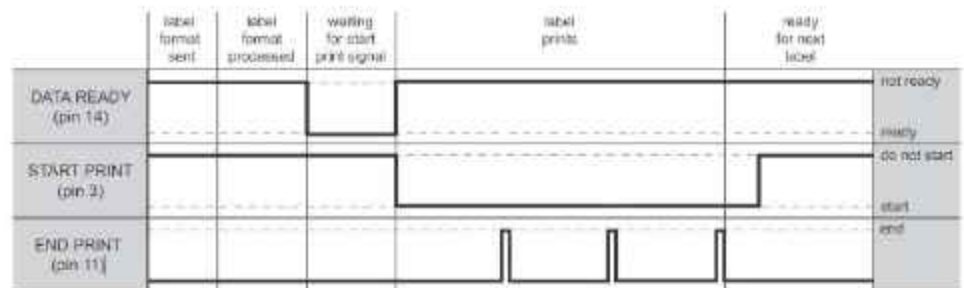

Configuring Applicator Port Settings

The applicator interface supports three different applicator modes:

- [Z-Style Port](#)
- [S-Style Port](#)
- **I-Style Port.** This mode combines Z-Style or S-Style settings with the ability to trigger external I/O systems via the External Error port.

You can configure applicator port settings from the web browser interface or in Setup Mode.

Web Browser Interface

1. From the menu, click **System Settings > Manage I/O**. The configuration screen appears.
2. Chose **Enable** from the drop down list for the Applicator.
3. From the menu, click **Configure > Printing > Applicator**.
4. Choose desired settings from the drop down lists.

Setting	Description
Style	I-Style, Z-Style, S-Style
Startprint	Level or Pulse
Endprint	Mode 0, Mode 1/Type3, Mode2/Type4, Mode3/Type 1, Mode 4/Type 2
Ribbon/Media Low	Enables/disables the printer low ribbon alert message. Enables/disables the printer low media alert message.
Reprint	Enables/disables reprinting the last label sent to the printer (by using the Reprint signal)
Error on Pause	Enable this setting to set the "Service Required" signal when the printer is paused. This setting supported by Z-Style only.
Error Port	Enables/disables the printer external error port.
RTW	Configures the Ready-to-Work output signal (RTWOUTEXT). Choose from: <ul style="list-style-type: none">• Mode 1 - Signal is asserted low when no events are active in the System Health Monitor (SHM).• Mode 2 - Signal is asserted low when the printer motor is idle.• Mode 3 - Signal is asserted low when the printer motor is idle and no events are active in the SHM.
DC 5V	Configures the printer to use either its internal power supply or an external supply (connected to the External Power port) to provide +5VDC to the Z-Style and S-Style ports.

Setting	Description
DC 24V	Configures the printer to use either its internal power supply or an external supply (connected to the External Power port) to provide +24VDC to the Z-Style and S-Style ports.

5. Click **Save**. The settings are saved.

Setup Mode

Use the printer touch screen to view and change settings.

1. Press **Menu > Settings > System Settings > Manage I/O**.
2. Choose **Enable** from the drop-down list for the applicator.
3. From the menu, select **Menu > Settings > Printing > Applicator**.

About Applicator Input Signals

This section describes the INPUT signals.

Note: All IN signals are asserted low and de-asserted high.

Signal	Description
Startprint	Starts a print job. Choose either Level or Pulse. <ul style="list-style-type: none"> • Level: The printer starts printing labels when the startprint signal is asserted and continues printing until the signal is de-asserted. • Pulse: The printer prints one label when the startprint signal is asserted. The startprint signal must be de-asserted and then asserted to print the next label.
Feed	Feeds a single label. Not supported by S-Style.
Pause	Toggles between Pause mode and printing. Not supported by S-Style.
Reprint	Reprints the last valid label.
Apperr1	Applicator error 1.
Apperr2	Applicator error 2.
Apperr3	Applicator error 3.
RTWINEXT	External input signal, which you can use to monitor the operational status of the entire system.

About Applicator OUT Signals

This section describes the Applicator OUT signals.

Note: Unless described otherwise, all OUT signals are asserted low and de-asserted high.

Signal	Description
Data Ready	Asserted when the printer is ready to receive a startprint signal and execute the current print job. De-asserted when the print cycle ends. Not supported by S-Style.

Signal	Description
Endprint	<p>Asserted during or after a print cycle. The endprint signal also behaves differently depending on the applicator port endprint mode. When the startprint signal is received, the endprint signal may or may not be asserted.</p> <p>There are five options to choose from:</p> <ul style="list-style-type: none"> • Mode 0: Endprint signal is never asserted. • Mode 1 (Z-Style)/Type 3 (S-Style): Asserted low during print/feed cycle. • Mode 2 (Z-Style)/Type 4 (S-Style): Asserted high during print/feed cycle. • Mode 3 (Z-Style)/Type 1 (S-Style): Asserted low for at least 20 ms after print/feed cycle end. • Mode 4 (Z-Style)/Type 2 (S-Style): Asserted high for at least 20 ms after print/feed cycle end.
Media out	<p>Asserted when the printer is out of media. Activates an SHM PaperOut event in the System Health Monitor (SHM). De-asserted when the same event is deactivated.</p>
Ribbon/Media low	<p>Asserted when the ribbon/media roll diameter drops below a predefined level. De-asserted while the roll diameter remains above the predefined level.</p> <p>Media low is supported only by I-Style.</p>
Ribbon out	<p>Asserted when the printer is out of ribbon. Activates an SHM RibbonOut event in the System Health Monitor (SHM). De-asserted when the same event is deactivated.</p>
RTWOUTEXT	<p>External output signal.</p> <p>Behavior depends on the current setup. Signal may be asserted when there are no active events in the System Health Monitor (SHM), when the printer motor is idle, or both.</p> <p>This signal is inactive when the Error Port option is disabled.</p>
SERVICEREQ (Service Required)	<p>Asserted low when an event in the System Health Monitor (SHM) is activated. De-asserted when no events are active in the SHM.</p> <p>A "service required" event is also activated when the Error Port is enabled and any applicator errors is detected. This signal is also asserted when the Error on Pause option is enabled.</p>

Programming Applications for the printer

The printer includes Honeywell Fingerprint, a programming language that resides on the printer. Fingerprint is an easy-to-use programming tool for label formatting and printer customization.

Fingerprint also includes a slave protocol, Honeywell Direct Protocol, which allows layouts and variable data to be downloaded from a host and combined into labels, tickets, and tags with a minimum of programming. Honeywell Direct Protocol also includes a versatile error handler and a flexible counter function.

Fingerprint Commands for the printer

The ON PORTIN, PORTIN, PORTOUT, and ON PORTOUT Fingerprint commands support applicator functionality for the printer. These commands are functional when the printer applicator port status is enabled.

This section includes basic information for each of these commands. For more information, see the Fingerprint Command reference manual.

ON PORTIN

This command allows a Fingerprint application to detect in signals. If a particular in signal is asserted, the application moves to the subroutine responsible for carrying out tasks related to that in signal. One command is available for detection of each of the 8 in signals.

Note: *This command is not supported by Honeywell Direct Protocol.*

Example:

- ON PORTIN.STARTPRINT GOSUB nnn

PORTIN

This command is a version of the PORTIN(PORT) command and checks the current state of a specified signal. This command returns -1 if the signal is asserted, or 0 if the signal is de-asserted.

Note: *This command is supported by Fingerprint and Direct Protocol.*

Example:

- PORTIN.STARTPRINT
- or
- PORTIN.RIBBONLOW

PORTOUT

Supports manually modifying the dataready signal. PORTOUT is not allowed when the applicator port style is set to S-Style.

Note: *This command is not supported by Direct Protocol.*

Example:

- PORTOUT.DATAREADY ON
- PORTOUT DATAREADY OFF

where *on* asserts the dataready signal low and *off* de-asserts the dataready signal high.

ON PORTOUT

This command allows a Fingerprint application to detect when out signals have been reset to default values. The command moves to a specified subroutine whenever the applicator port status is enabled, and whenever the applicator port style is changed.

Example:

- ON PORTOUT.RESET GOSUB nnn

Using External Applicator Signals

The printer responds to external applicator port signals differently, depending on whether your application is using Fingerprint or Honeywell Direct Protocol.

Fingerprint and Applicator Signals

When you use Fingerprint, all in signals and the Data-ready out signal are handled by Fingerprint. Other out signals are handled by firmware.

Feed

When the Feed in signal is received, the application moves to a specified subroutine that feeds labels until the Feed in signal is de-asserted.

Example:

- 10 ON PORTIN.FEED GOSUB 200
...
200 FORMFEED
210 RETURN

Pause

When the Pause in signal is received, the application moves to a specified subroutine that finishes the current print job and then places the printer in pause mode.

Example:

- 10 ON PORTIN.PAUSE GOSUB 90
...
90 pause printer

Startprint

When the Startprint signal is received, the application moves to a specified subroutine that starts the print job. The Startprint signal must be preceded by the dataready signal as seen in this example.

Example:

- 10 PORTOUT.DATAREADY on
20 ON PORTIN.STARTPRINT GOSUB 60
...
60 my print routine
70 PRINTFEED
80 RETURN

Reprint

When the Reprint signal is received, the application moves to a specified subroutine that reprints the last valid label.

Example:

- ...
100 ON PORTIN.REPRINT GOSUB 150
...
150 PRINTFEED -1,1
160 RETURN

Printfeed

The dataready signal must be set manually by the Fingerprint application before a printfeed is issued when using with an applicator.

Handling External Applicator Errors

When an error signal (apperr1, apperr2, or apperr3) is received, the application moves to a specified subroutine that takes action based on error severity.

Example:

- ...
60 ON PORTIN.APPERR1 GOSUB 100
...
100 perform error handling
110 RETURN

Handling Internal System Errors

For internal system errors, the system error signal status can be read at any time within the application so appropriate measures can be taken. When any of these errors occur, the appropriate out signal (including the error) is asserted:

- Printhead lifted
- Ribbon out
- Media out
- General print engine fault
- Exceed maximum barcodes

Example:

- 10 IF PORTIN.RIBBONLOW GOTO 200
...
200 perform error handling
210 RETURN

Resetting Out Signals

Out signals are reset to their default values when certain options are changed by using the SETUP menu. When the reset is detected, the application moves to a specified subroutine and performs the tasks necessary to reinitialize the print engine.

Example:

- 10 ON PORTOUT.RESET GOSUB 150
- ...
- 150 perform initialization
- 160 RETURN

Direct Protocol and Applicator Signals

In Direct Protocol, all in and out signals are handled by the Direct Protocol firmware.

Feed

There are two ways to trigger blank label feeding:

- by manually pressing Feed on the printer front panel. The printer feeds a single blank label.
- by using the Feed in signal. When this signal is detected, the printer feeds blank labels as long as internal applicator flag indicates that the Feed signal is asserted.

Pause

The applicator can toggle the current pause state by using the pause in signal to simulate pressing Pause on the printer front panel. When the printer is in pause state, you can press Setup on the printer front panel and place the print engine in Setup Mode for manual configuration.

Startprint

When the printfeed command is executed, the print process sets the dataready signal and then waits for the startprint signal to be detected before proceeding with the print job.

The print process will not set another dataready signal until the current print job de-asserts the previous dataready signal. This prevents the printer from printing a new label before the previous label is completed.

Reprint

This signal works much the same way as startprint. The reprint signal is detected under two conditions:

- when the printer is idle.

- when the printer is waiting for a startprint signal during the execution of a printfeed command.

The printer prints only one label at a time.

Handling External Applicator Errors

The external applicator error in signals (APPERR1, APPERR2, APPERR3, RTWINEXT) should be asserted when external applicator errors occur. When one of these signals is detected, an associated event is activated in the System Health Monitor (SHM). When the issue causing the error has been resolved and the error signals are de-asserted, the events are deactivated in the SHM.

Handling Internal System Errors

When a system error occurs that activates an event in the SHM, the “service required” signal is asserted. The external RTW out signal can be de-asserted, depending on the current print engine RTW setting.

When any of these errors occur, the appropriate out signal (including the error) is asserted:

- Printhead lifted
- Ribbon out
- Media out
- General print engine fault
- Exceed maximum barcodes

Error Messages

	ERRNOAPP
Message:	Operation not allowed. Applicator Port disabled.
Cause:	Application sent an applicator port command to the printer and the applicator port is disabled.
Error Number:	88
	ERRAPP
Message:	Operation not allowed. Applicator Port enabled.
Cause:	Application sent the Fingerprint command PORTOUT(PORT) ON/OFF on a port used by the applicator port when the applicator port is enabled.
Error Number:	89
	ERRINPUTON
Message:	Operation not allowed in Direct Protocol.

Cause: Running the PORTOUT.DATAREADY ON|OFF or PORTIN.<SIGNAL> GOSUB XXX commands when the printer is using Direct Protocol.

Error Number: 90

EAPPERR1

Message: Applicator Error 1.

Cause: AppErr1 in signal detected.

Result: Activates event in System Health Monitor (SHM).

Error Number: 1340

EAPPERR2

Message: Applicator Error 2.

Cause: AppErr2 in signal detected.

Result: Activates event in System Health Monitor (SHM).

Error Number: 1341

EAPPERR3

Message: Applicator Error 3.

Cause: AppErr3 in signal detected.

Result: Activates event in System Health Monitor (SHM).

Error Number: 1342

ERTWINEXT

Message: RTW External Error.

Cause: RTWExternal in signal detected.

Result: Activates event in System Health Monitor (SHM).

Error Number: 1343

ENODATAREADY

Message: Dataready not enabled.

Cause: Application sent a PRINTFEED in Fingerprint when the applicator port is enabled, the style is set to I-Style or Z-Style, and the dataready signal is not enabled.

Result: Terminates the printfeed command without printing a label.

Error Number: 1344

Display Messages

These messages appear in the printer display under certain conditions when a PRINTFEED command is run.

- Message:** APPLICATOR PORT: Wait for signal.
Running a PRINTFEED command blocks execution until a startprint signal is received. The message appears when execution has been blocked for a few seconds.
- Cause:**
- Message:** APPLICATOR PORT: Wait for reprint.
Running a PRINTFEED -1,1 command blocks execution until a reprint signal is received. The message appears when execution has been blocked for a few seconds.
- Cause:**

Wi-Fi/Bluetooth Interface Board

This section describe how to install the Wi-Fi/Bluetooth board on the PM45 and PM45c printer.

Out of the box

- Wi-Fi/Bluetooth Module
- Antenna

Installation

You will need a T20 Torx screwdriver to install the Wi-Fi/Bluetooth Module.

1. Remove the small antenna cover and the two screws that secure the small cover plate to the printer.

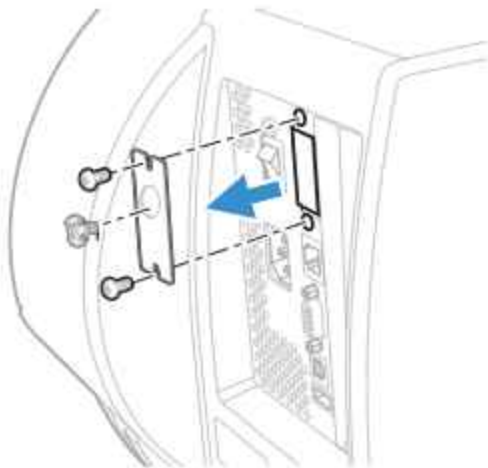

2. Insert the cover plate to the Wi-Fi/Bluetooth board and affix it with the hex washer.

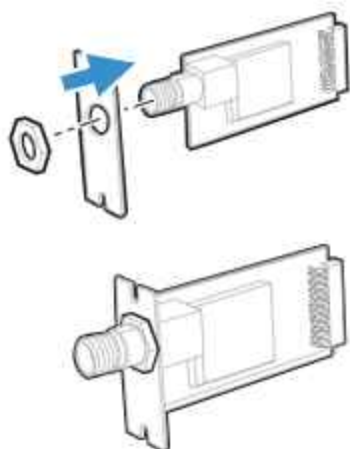

3. Insert the Wi-Fi/Bluetooth board into the printer and secure the board with the two screws you removed in step 1.

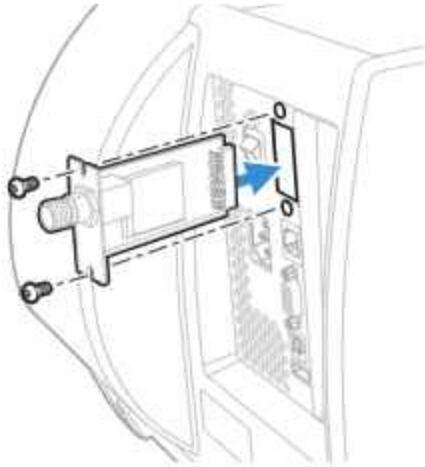

4. Connect the antenna to the antenna connector on the back plate.

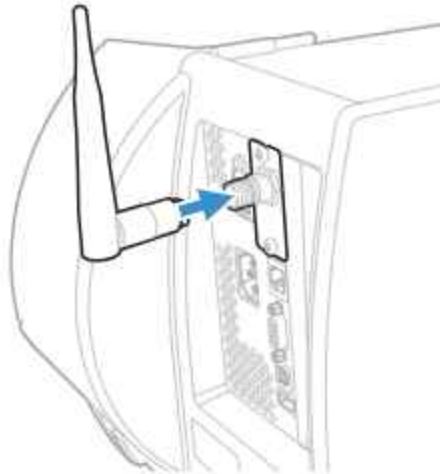

Note: To learn more about configuring Wi-Fi, see the PM45 and PM45c User Guide. To view the User Guide, visit the PM45 product page at www.sps.honeywell.com.

INSTALLING ACCESSORIES

Label Dispenser

The label dispenser accessory for the PM45 and PM45c printer self-strips the label and removes the liner from the self-adhesive label stock.

Out of the Box

- Label dispenser

Installation

You will need a torx screwdriver to install the label dispenser.

1. Open media cover.
2. Remove the front access door. (See [page 6](#))
3. Remove the three screws that attach the tear bar to the printer and remove it.

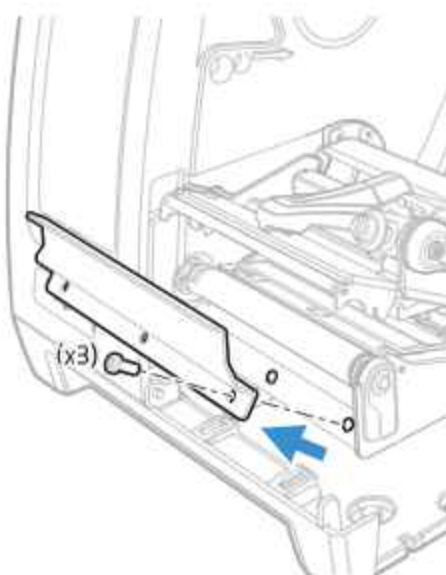

4. Align the label dispenser where the tear bar was removed, and affix using the previously removed three screws.

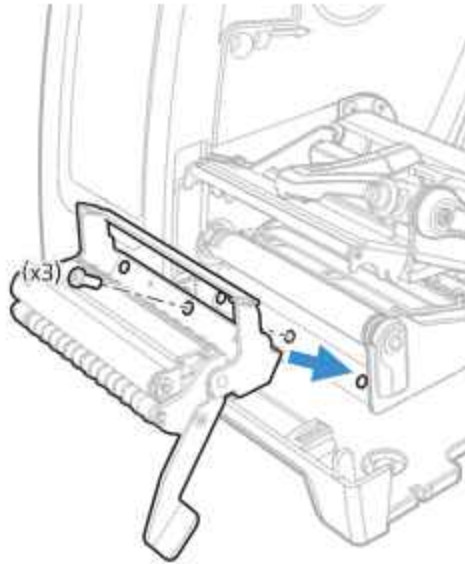

5. Route the media through the label dispenser.

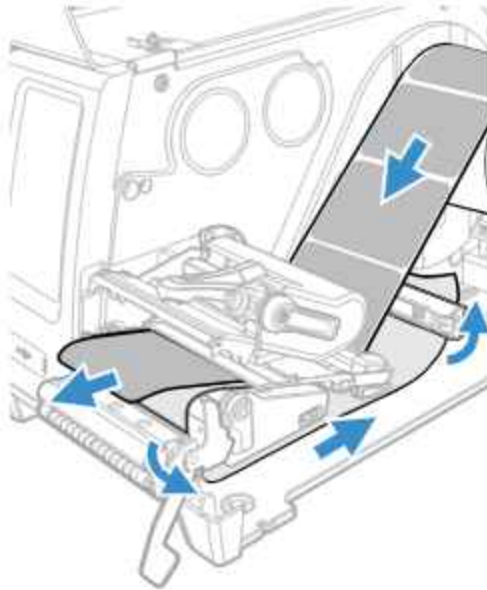

6. Pull the label dispenser lever up.

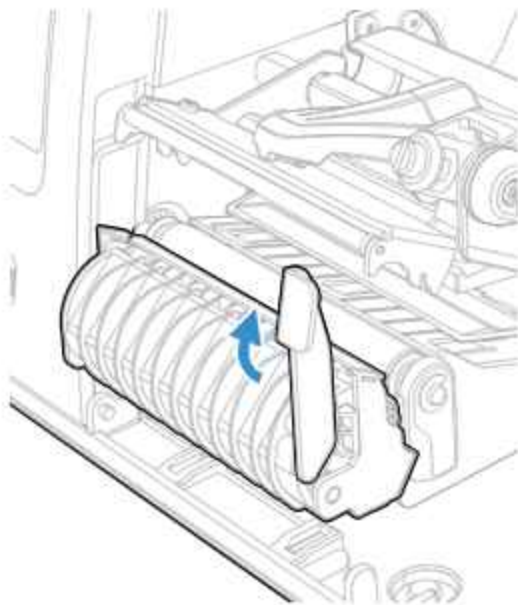

7. Close the media cover.

Cutter Module

Cutter modules for PM45 and PM45c come with standard cutter module for non adhesive labels and a cutter with adhesive resistant blades for adhesive labels.

The installation procedure is same for both models of cutter.

Installing Cutter Module for PM45 Printer

Use these instructions to install the cutter in the PM45 printer. You will find the following items in the shipping box.

- Standard Cutter module with bracket
- 4 Torx screws and 4 washers

You will need a Torx screwdriver to install the cutter module.



Warning: The cutter must only be installed by an authorized service technician.



Caution: Follow standard ESD guidelines to avoid damaging the equipment you are servicing.



Caution: Before you begin, turn off the printer and disconnect the power cord and communication cables.

To install the standard cutter module,

1. Remove the media cover. (See [page 3](#))
2. Remove the front access door. (See [page 6](#))

3. Remove the three screws that attach the tear bar to the printer and remove it.

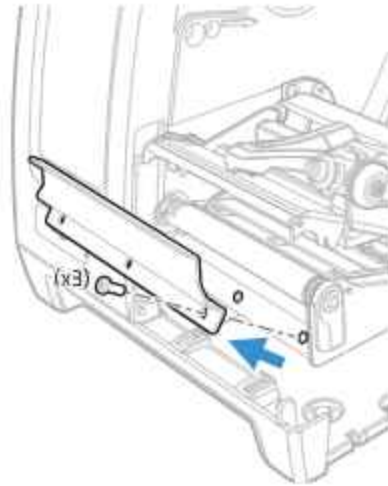

4. Carefully turn the printer on its side and align the cutter bracket with the holes in the base of the printer.

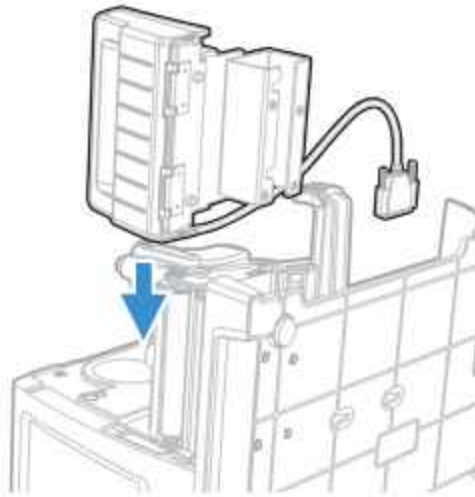

5. Attach the cutter bracket to the printer base with the four Torx screws and washers.

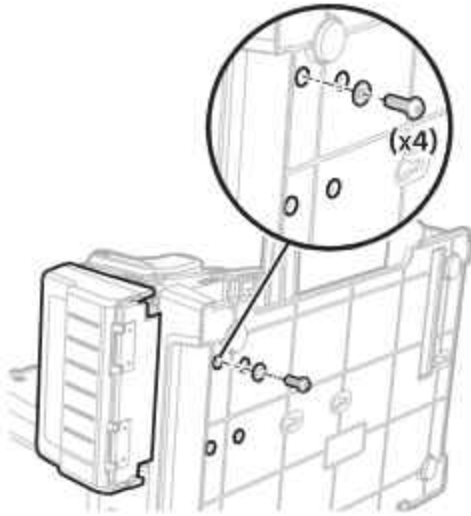

6. Turn the printer back upright and connect the cutter cable on the electronics side of the printer.

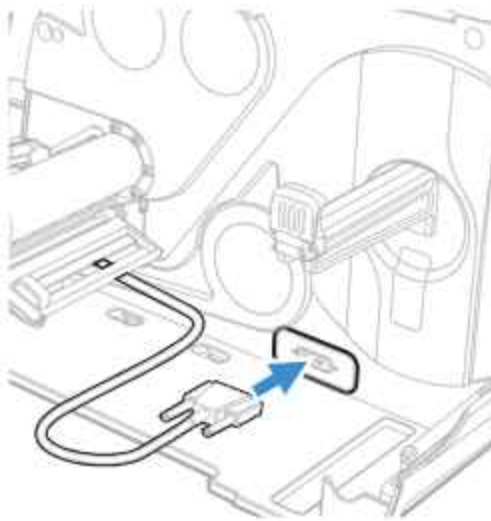

7. Route the media through the printer and out through the cutter.

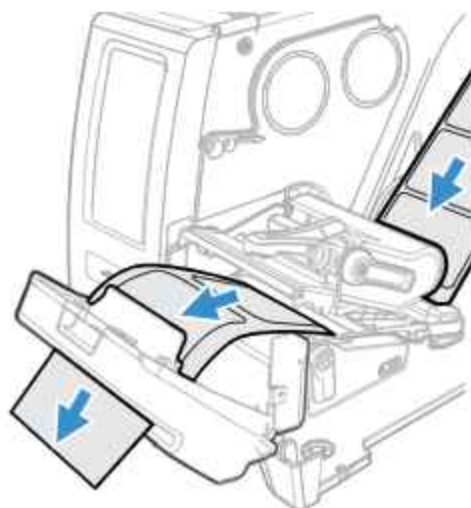

8. Close the printhead and close the media cover.

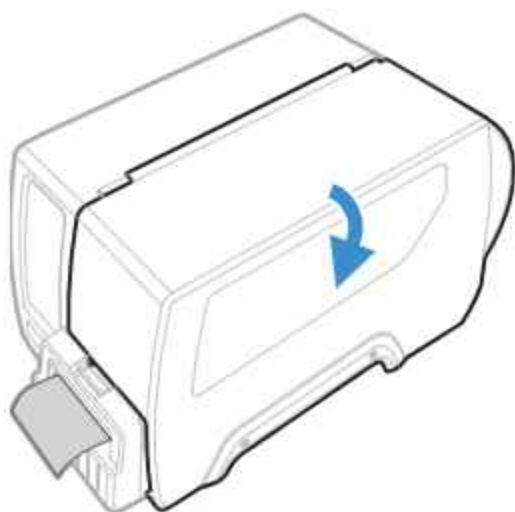

Installing Cutter Module for PM45c Printer

Use these instructions to install the cutter in the PM45 printer. You will find the below items in the shipping box.

- Standard Cutter module
- 4 Torx screws and 4 washers

You will need a Torx screwdriver to install the cutter module.



Warning: The cutter must only be installed by an authorized service technician.



Caution: Follow standard ESD guidelines to avoid damaging the equipment you are servicing.



Caution: Before you begin, turn off the printer and disconnect the power cord and communication cables.

To install the standard cutter module,

1. Remove the media cover. (See [page 3](#))
2. Remove the front access door. (See [page 6](#))
3. Remove the three screws that attach the tear bar to the printer and remove it.

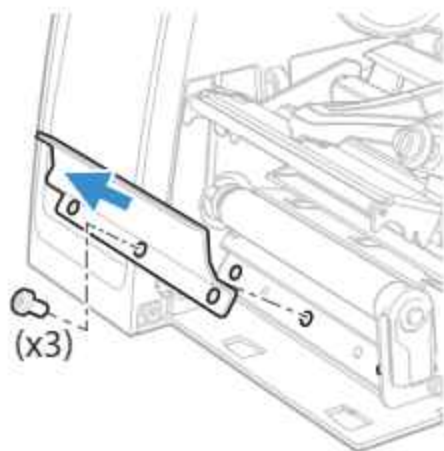

4. Remove the electronics cover. (See [page 5](#))

5. Remove the three screws that attach the UI cover to the printer and open the cover. Do not disconnect the UI cable as you lay the cover on its side.



6. Connect one end of the cutter cable to the main logic board.

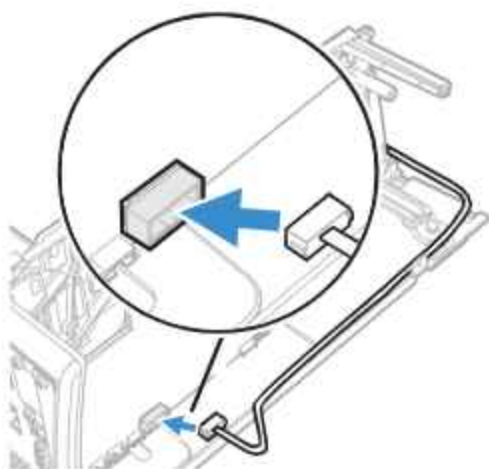

7. Route the cutter cable through the printer and out behind the UI cover. Use the two cable retainers to secure the cutter cable in place.

8. Replace UI cover and attach it with the three screws removed in step 5.



9. Connect the other end of the cutter cable to the cutter.

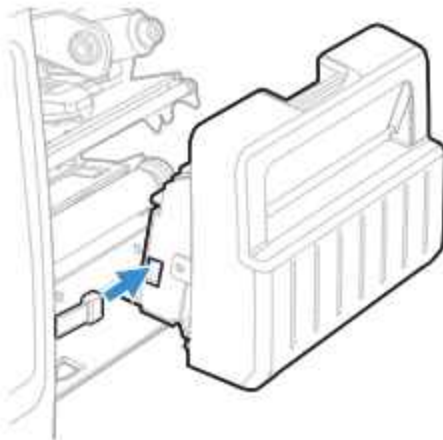

10. Replace the electronics cover.

11. Carefully turn the printer on its side and align the cutter with the holes in base of the printer.

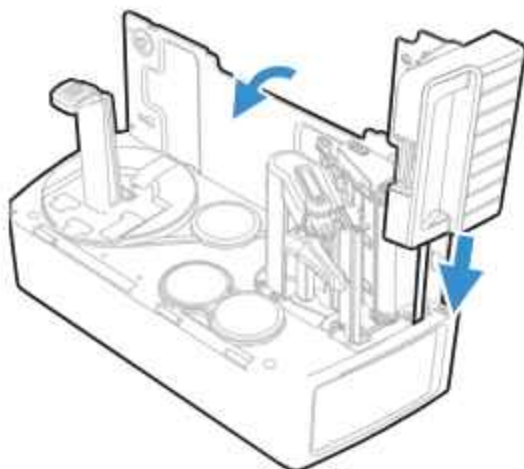

12. Attach the cutter to the printer base with the four Torx screws and washers.

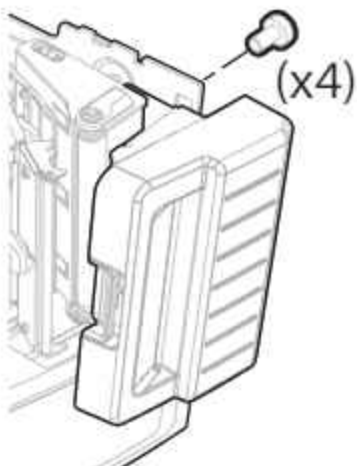

13. Turn the printer back upright.
14. Replace the media cover.

15. Route the media through the printer and out through the cutter.

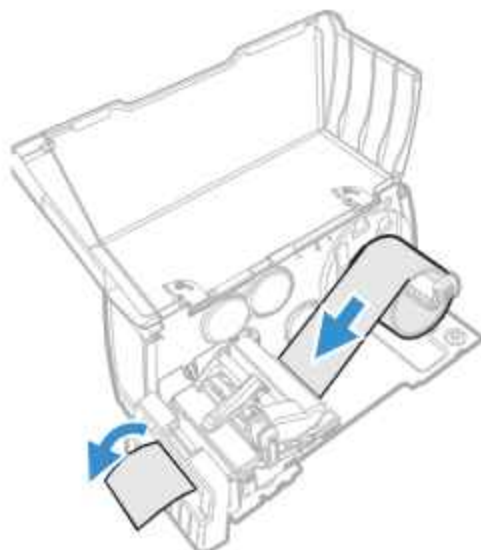

16. Close the printhead.

17. Close the media cover.

3-inch Media Core

The 3" inch media core can be used as an adapter for 3" diameter media cores. This accessory can be used in both PM45 and PM45c printers.

Out of the Box

- 3" Media Core

Installation

1. Open the media cover.
2. Insert the 3" media core.

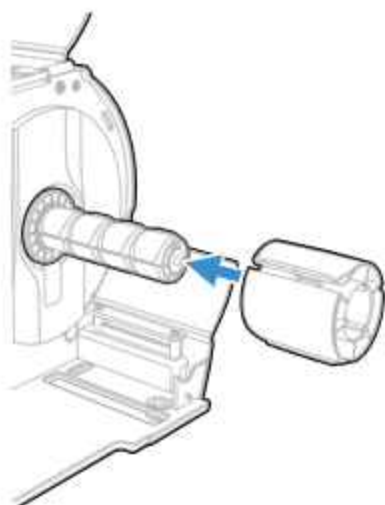

3. Insert the 3" diameter media.

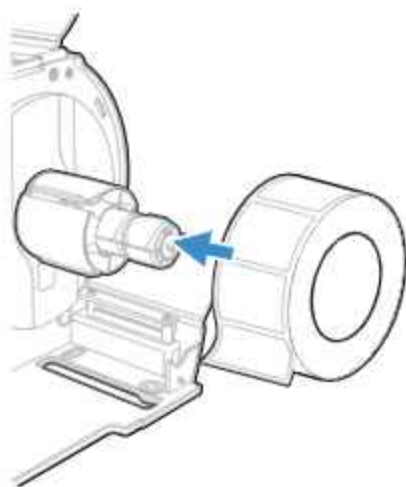

4. Close the media cover.

Collapsible Core

The collapsible core accessory can be used for coreless media rewinding for both PM45 and PM45c printers.

Out of the Box

- Collapsible core

Installation

You will require a Phillips screwdriver to install the collapsible core.

1. Open the media cover.

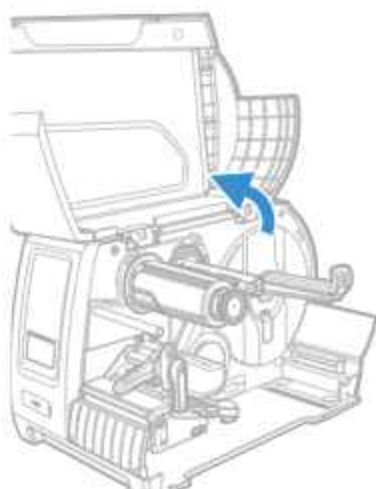

2. Remove the screw on the collapsible core.

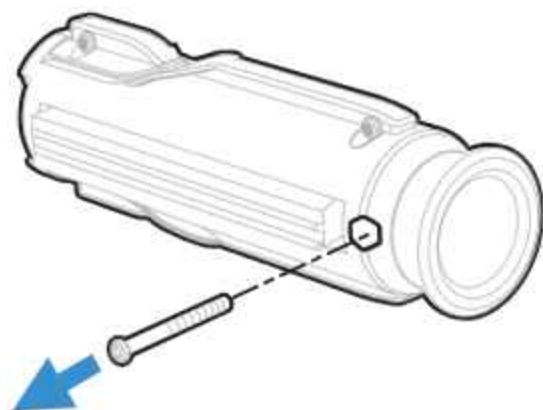

3. Insert the collapsible core onto the media rewinder below.

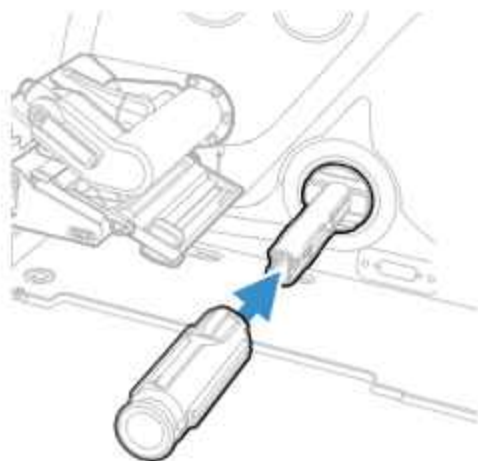

4. Insert the screw back onto the collapsible core and tighten it using a torx screwdriver.

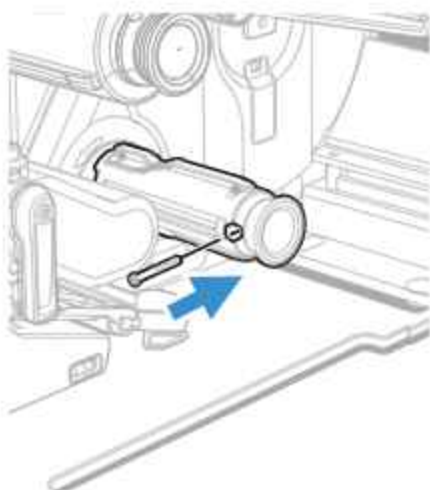

5. Route the liner/label edge on the collapsible core and rotate anticlockwise to secure liner/label on the collapsible core.



6. Pull the collapsible hub to release the liner/label from the collapsible core.

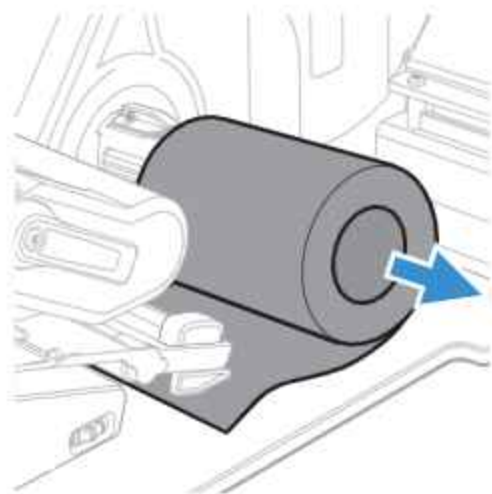
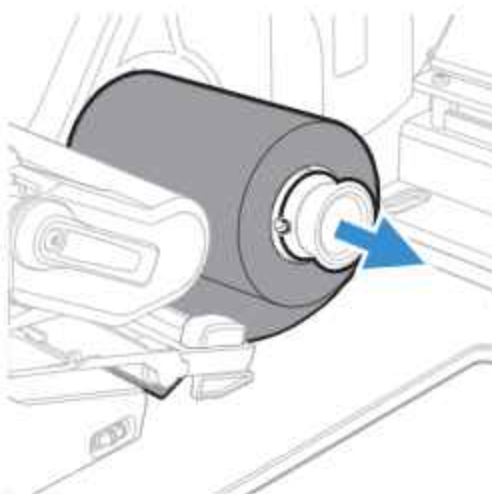

Full Batch Rewinder

The full batch rewinder accessory can rewind a full batch of 8" media roll. The accessory comes with a bottom extended enclosure, internal rewind mechanism and a cut out base.

This accessory is compatible with PM45 printer.

Out of the Box

- Extended base rewinder
- Batch plate
- 3 Torx screws

Installation

You will need these tools to install the full batch rewinder.

- #T20 Torx screw
- Small wrench

To install the full batch rewinder,

1. Remove the media cover. (See [page 3](#))
2. Remove the electronics cover. (See [page 5](#))
3. Remove the front access door. (See [page 6](#))
4. Remove the three screws that connect the tear bar to the printer and remove it.

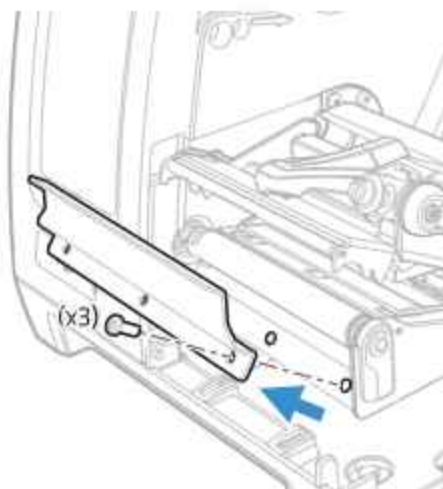

5. Attach the batch plate with the three screws you removed from the tear bar in Step 4.

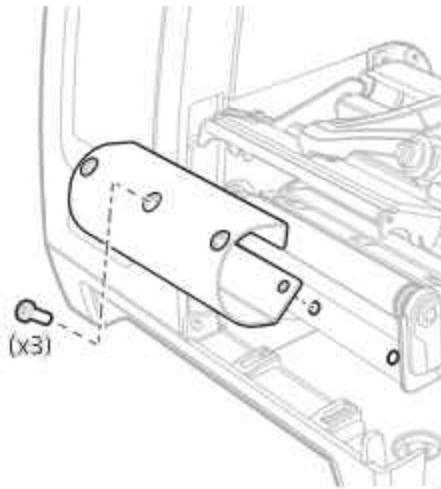

6. Remove the five screws that attach the printer spine to the base.

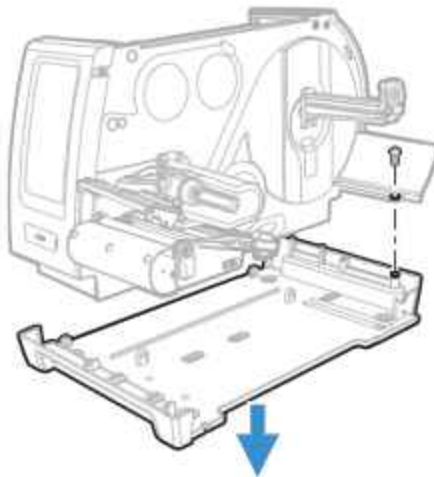

7. Lift the spine away from the printer base.

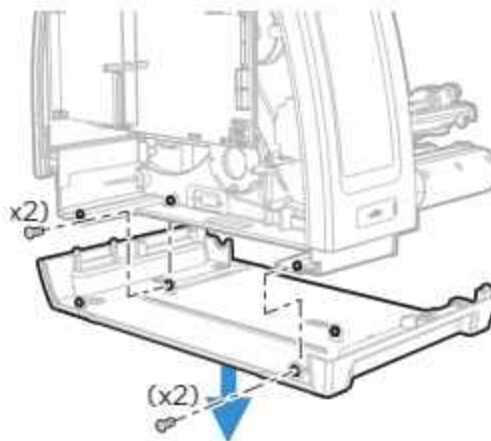

8. Attach the spine to the full batch rewinder with the five screws removed in step 6 (see [page 68](#)).

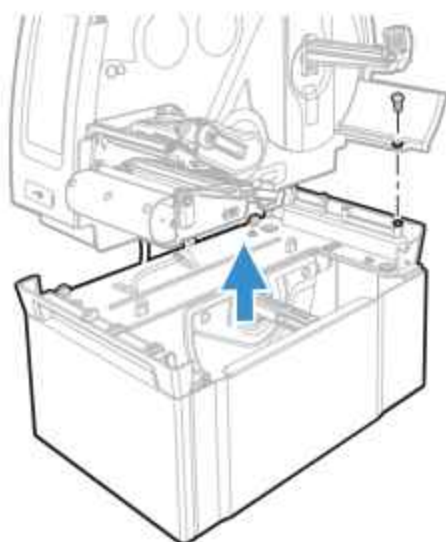

9. Connect the grounding strap to the printer base with one of the screws.

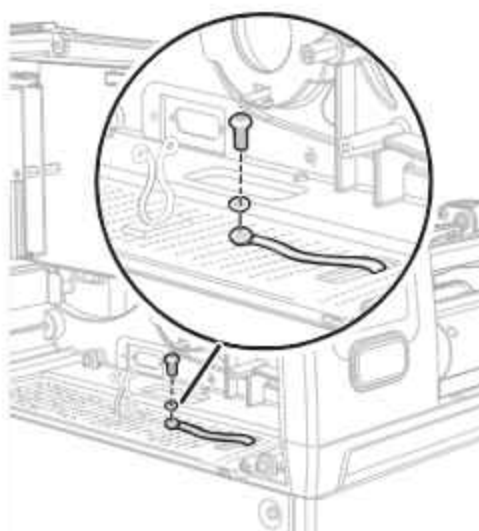

10. Feel the full batch rewinder cable through the cable clip and then insert it into the J24 connector on the main logic board.

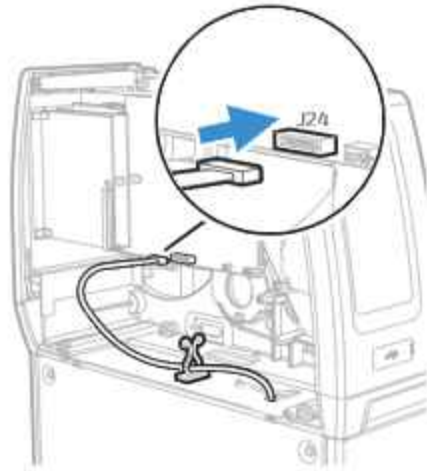

11. Replace the media cover and electronics cover.
12. Open the full roll rewinder door and move the media roll guide out to the edge of the base.

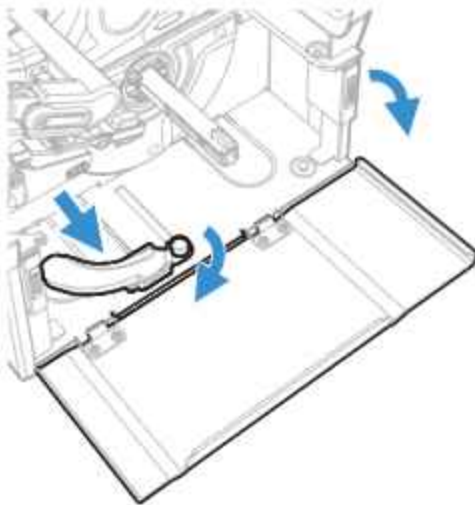

13. Raise the media roll guide to the upright position and insert the cardboard core onto the media roll rewinder hub.

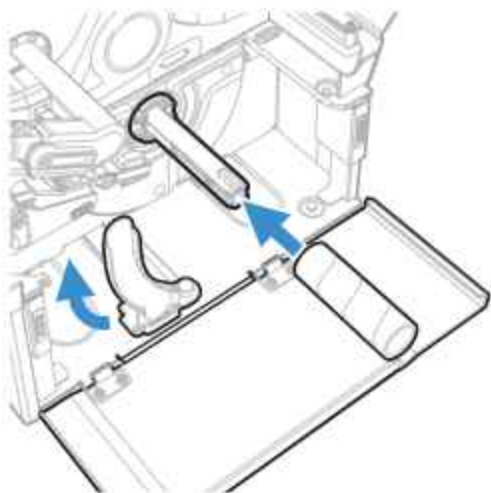

14. Close the full batch rewinder door.
15. Close the media cover.

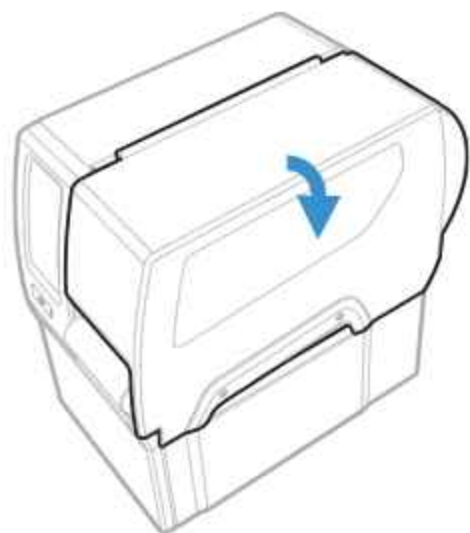

Large Media Edge Arm Guide

The large media arm edge guide accessory prevents horizontal skewing of large media rolls.

This accessory is compatible with PM45 printer.

Out of the Box

- Large media arm edge guide

Installation

You will require a Torx screw driver to install the accessory.

To install the large arm edge media guide,

1. Bring the arm edge guide to the far end of arm and turn 90 degrees clockwise direction.

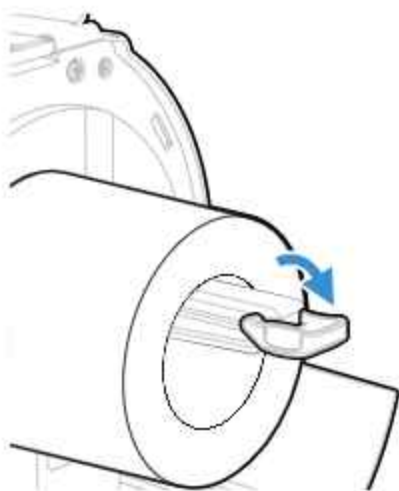

2. Insert the torx screw driver between the arm and guide and twist the screw driver counter clockwise direction to remove the small arm guide.

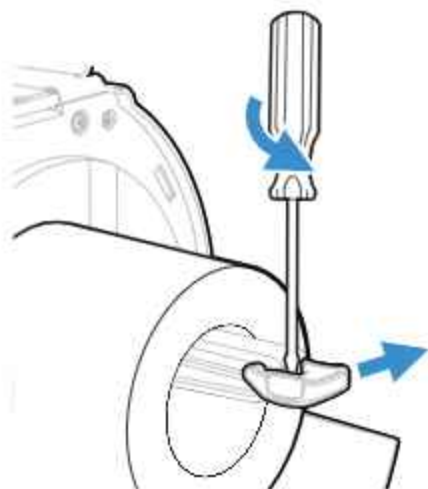

3. Squeeze in the large arm guide onto the arm.

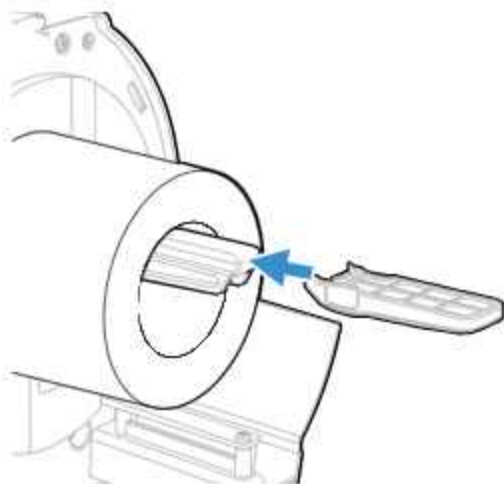

4. Turn the large arm guide upright to place in position.



Short Media Cover

The PM45c printer has option to install short media cover to hold larger media core.

Out of the Box

- Short media cover
- Two #T20 screws
- Long Hinge bracket

Installation

You will require a small wrench and a torx screwdriver to install the short media cover.

1. Remove the standard media cover. (See [page 3](#))
2. Align the short media cover on the hinges.

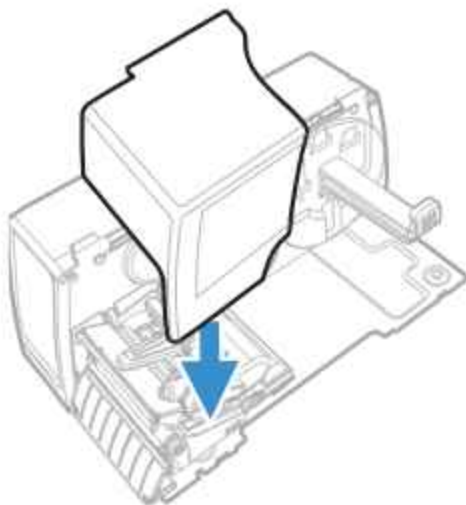

3. Open the short media cover.

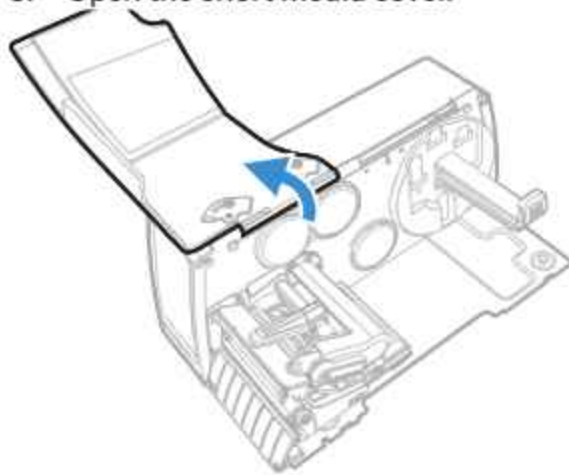

4. Slide the latches clockwise and tighten the nut using the small wrench.

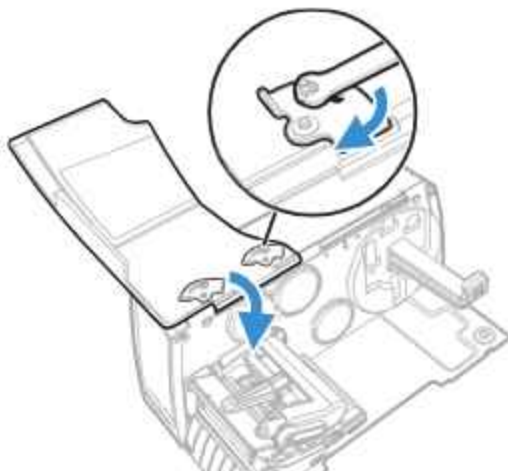

5. Affix the long hinge bracket using the torx screwdriver at the back of the printer.

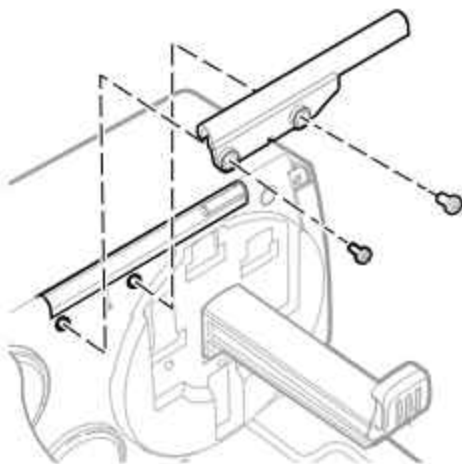

6. Close the short media cover.

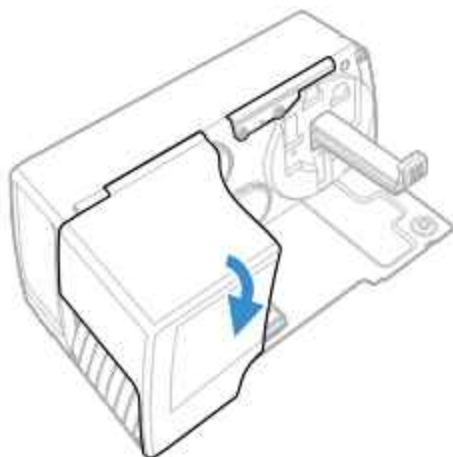

Dome Media Cover

The PM45c printer has option to install dome media cover to hold larger media core and to protect the inside of the printer from dust and debris.

Out of the Box

- Dome media cover
- Transparent dome
- Two #T20 screws

Installation

You will require a small wrench and a torx screwdriver to install the short media cover.

1. Remove the standard media cover. (See [page 3](#))
2. Remove the two torx screws located at the back of printer.

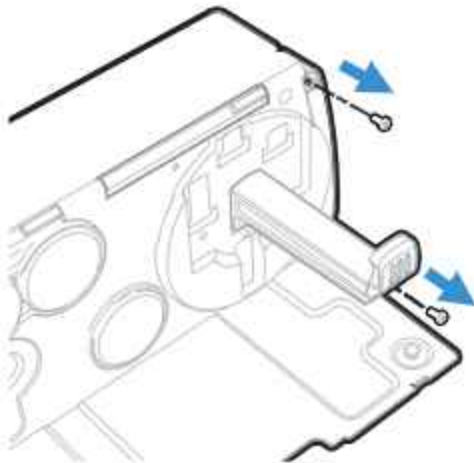

3. Align the transparent dome cover on the back and replace the screws removed in Step 2.

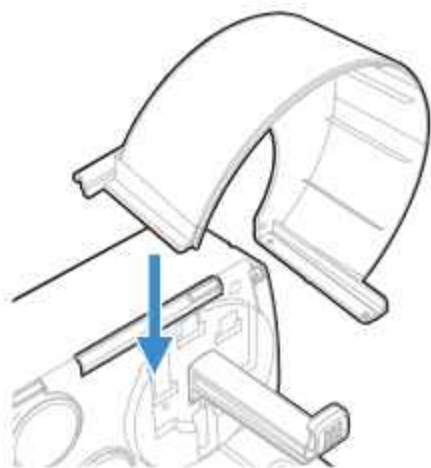

4. Affix two torx screws on the base of printer.

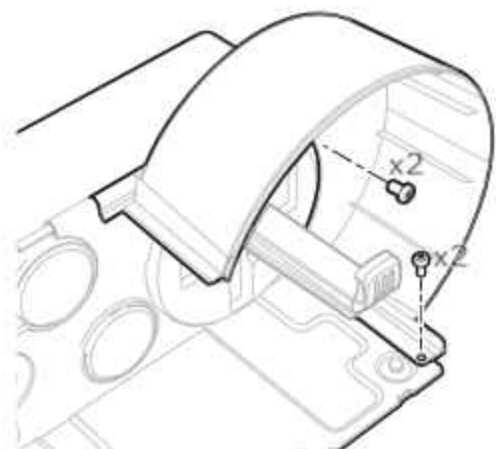

5. Align the dome cover on top of the printer.

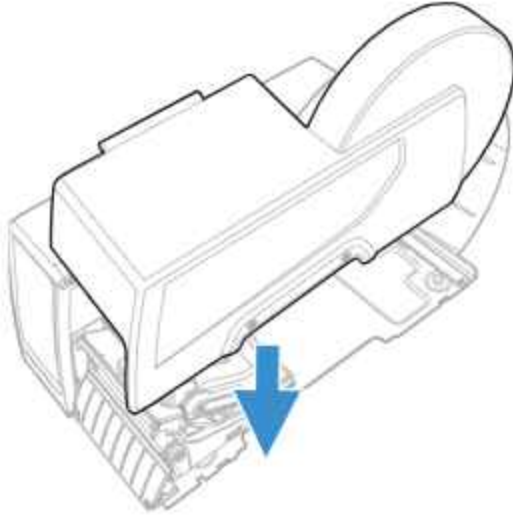

6. Open the dome cover and tighten the latches by turning it clockwise direction using a small wrench.



7. Close the dome cover.

Thermal Printhead

The thermal printhead for PM45 and PM45c printers are available in 203, 300, 406, 600 dpi. The installation procedure is same for both printer models.

Out of the Box

- Thermal printhead

Installation

1. Open the media cover.
2. Turn the printhead lever counterclockwise to raise the printhead.



3. Detach the magnetic pressure arm from the printhead bracket and disconnect the two cables from the existing printhead as you remove it from the printer.



4. Insert the new printhead and connect the two printhead cables.



5. As you insert the new printhead bracket into the printer, make sure the metal arms on the printhead go around the magnetic pressure arm bar. Attach the magnetic pressure arm to the printhead.
6. Restart the printer for the firmware to detect the new printhead.

WALL MOUNTING TEMPLATE

PM45 Wall Mounting Template

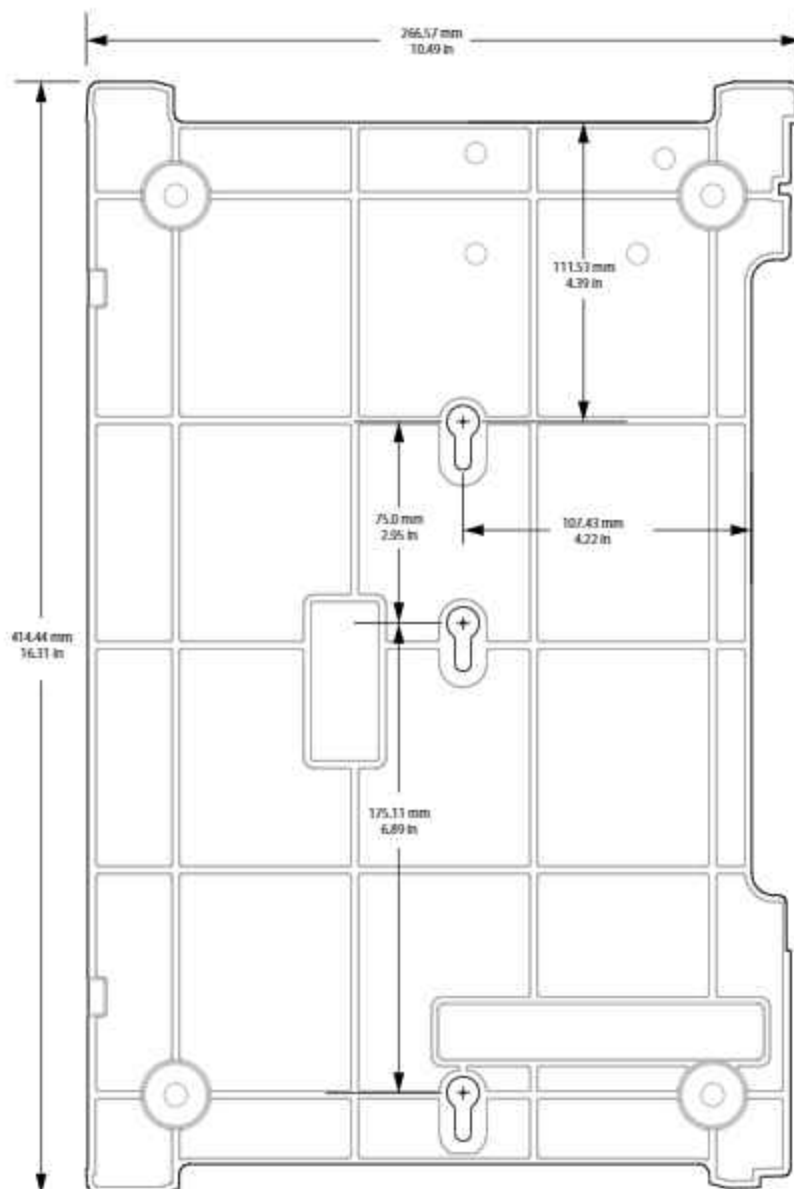

PM45c Wall Mounting Template

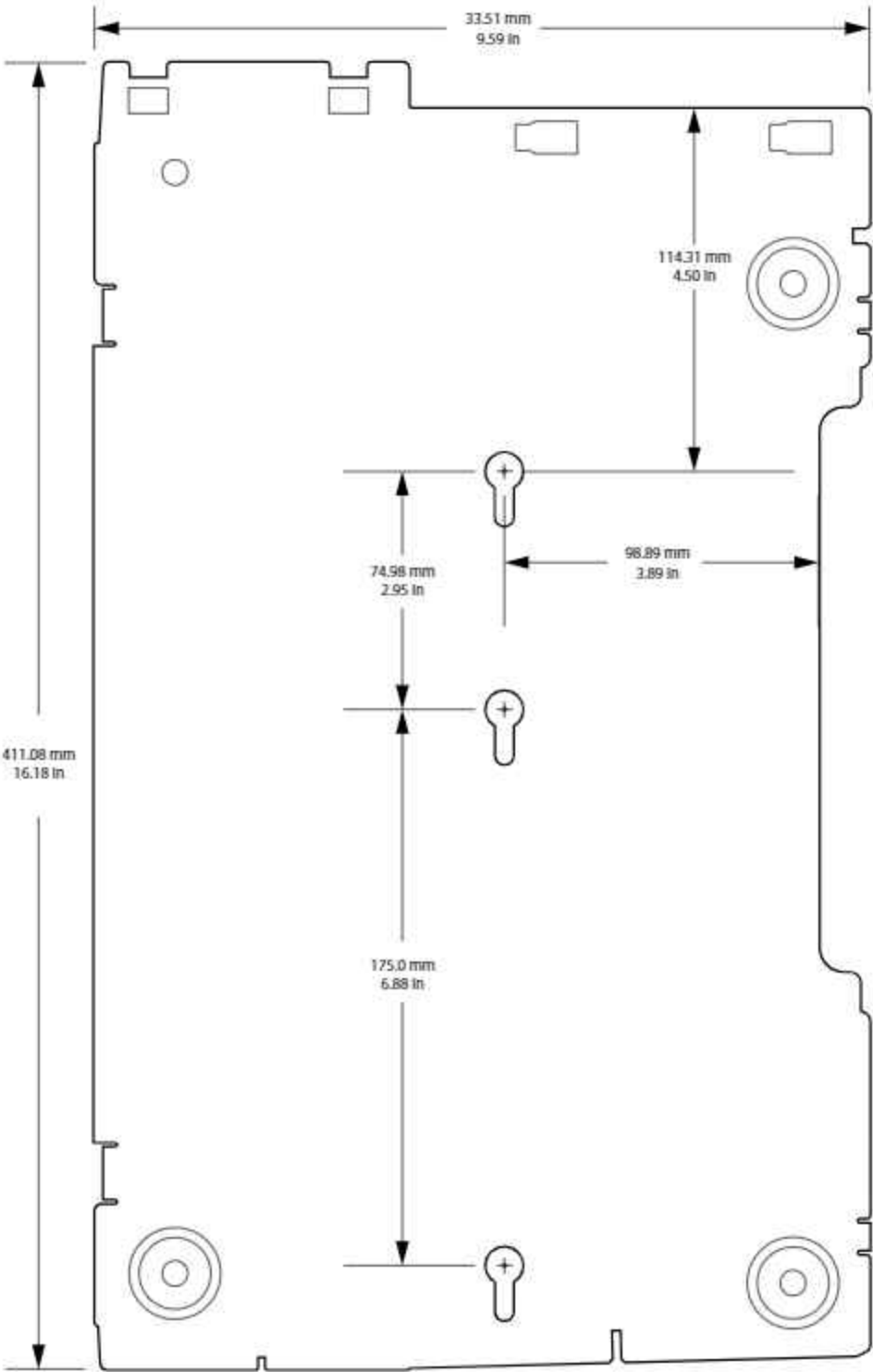

Honeywell
855 S. Mint Street
Charlotte, NC 28202

www.sps.honeywell.com